



Shaping Our Future

Marquard & Bahls AG | **Annual Report 2018**

Group Figures **2018**

Marquard & Bahls

14,728 million € consolidated revenues (including energy taxes)
7,561 employees

Oiltanking

20.3 million cbm tank capacity
153.1 million t throughput

Mabanaft

20.8 million t sales

Skytanking

23.2 million cbm throughput



*“The best way to predict the future
is to create it.”*

Abraham Lincoln

The world is in a state of flux. And this applies equally to us, to the society in which we live, and to the markets in which we operate.

And change itself is changing, becoming faster, more diverse, and making the future more difficult to predict – but also increasing the number of opportunities it offers. Taking advantage of the opportunities here and now and being part of change is the best way to shape the course of things.

To do this is our aspiration and the path we are on. Because we can only keep our future in our own hands if we keep developing ourselves.

Content

05	Entrée
06	Interview with the Executive Board
11	Holding
19	Tank Storage Logistics
31	Trading
43	Aviation Fuelling
50	Dry Bulk Handling
51	Biogas
52	Carbon Trading
53	Fuel Analysis
54	Energy Services
56	Sites Worldwide
58	Report of the Supervisory Board
59	Consolidated Financial Statements 2018
60	Consolidated Statement of Financial Position
62	Consolidated Statement of Comprehensive Income
64	Auditor's Opinion
68	Organigram
70	Addresses

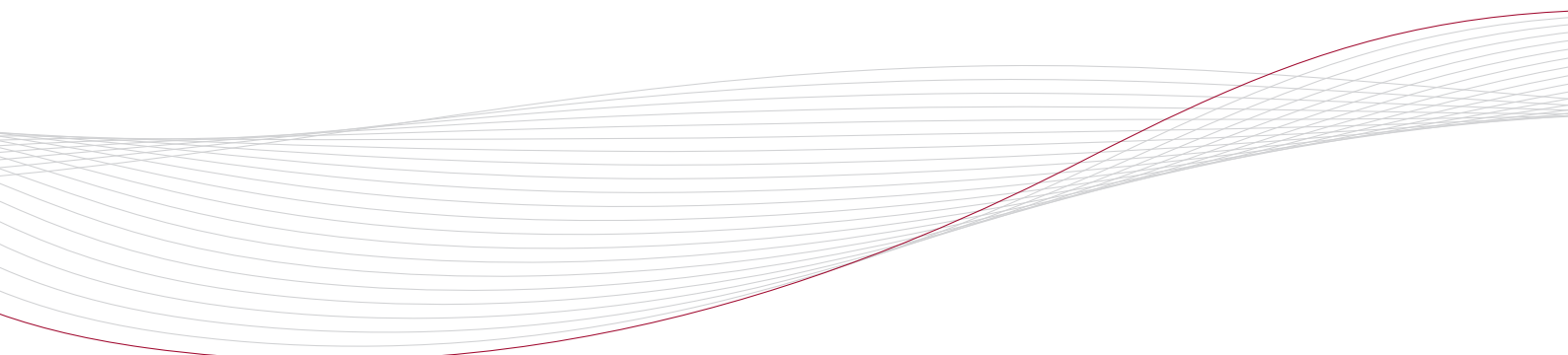

independent
sound
reliable

Welcome to Marquard & Bahls

Over the decades, we have grown into a leading independent company in the fields of tank storage logistics for oils, gases and chemicals; trading with petroleum products and gas; and aviation fuelling services.

There have been a lot of changes in the management lately. With our new management team, we intend to expand into new markets. What drives us? The joy of advancing our company and actively shaping the future.

We pursue sustainable growth by constantly expanding our knowledge and developing innovative solutions for our customers. Our culture is based on our confidence in our strengths – and on our values: respect, accountability, integrity, and responsibility.

And we will remain what we are: independent, sound, reliable.

Hamburg, April 2019



Daniel Weisser
Chairman of the Supervisory Board



“We Have a Lot of Potential”



Last year, there was a management changeover at Marquard & Bahls AG: With Mark Garrett as the new CEO and Lorenz Zwingmann as CFO, two new Directors have been “on board” since 2018. In our interview, they reflect on impressions from their first months with the company, talk about the challenges of the past year, and outline the Group’s future direction.

Mark, Lorenz, you’re both relatively new to Marquard & Bahls and have a fresh view on things. How does Marquard & Bahls differ from other companies?



Mark: The similarities outweigh the differences: Like everywhere else, employees here come to work to do a good job. They want to identify with their company and contribute to its success. The difference lies in our values and how we live them, and in our strategic decisions, which have a major influence on the company’s development and performance. This depends on the management making the right decisions – and that is precisely our job.

Lorenz: The difference lies in the culture. Marquard & Bahls has a distinctively welcoming culture that is geared towards collaboration. That’s a great strength. In contrast to other large companies, however, some processes are less clearly defined; that’s something we need to work on.

So you see a need for improvement with regard to the processes?

Mark: Much of what happens here is good and positive. The company is backed by a dedicated family, and good people work here. After all, Marquard & Bahls has been doing well since 1947 – so the company must have done a lot right. However, we do need to optimize our internal processes.

Lorenz: Between us, Mark and I can draw on more than 50 years of professional experience to find the best possible solutions. Having said that, the idea is not to reinvent everything, but rather to further develop existing structures.

Let's talk about 2018. What were the biggest challenges?

Mark: On the positive side, we achieved good operating results in our core areas of tank storage logistics, liquid and gas fuel provision, trading, and aviation fuelling, and we see a lot of potential for the future here as well. Our lowlights result from bad investments in the past, which continue to have an impact even now – but that can be corrected.

Lorenz: Despite the fact that we are currently making some adjustments, Marquard & Bahls is a healthy company. Even in the crisis years of 2008/2009, when many companies foundered, our company remained stable. And we have a clear plan for how we intend to develop Marquard & Bahls and our business areas. Of course, this also includes keeping an eye on costs.

What were the highlights at Oiltanking, Mabanft and Skytanking?

Mark: Oiltanking, our tank storage logistics subsidiary, delivered a solid performance in 2018, and has some promising projects in the pipeline. Mabanft, our trading organization, is also doing well: OILI and Petronord continue on their successful path, and the trading business picked up strongly towards the end of the year.

Lorenz: The acquisition of AGT (Antwerp Gas Terminal) two years ago is clearly a highlight – and an example of a smart investment decision. Oiltanking AGT is very successful – and continues to grow, including with the world's largest butane tank, which is currently under construction. Skytanking is also on track for growth: New sites in Turkey, India and the U.S. were recently added, and its market entry in Spain is coming up shortly.



Mark: 2018 was initially a difficult year for trading, as there was hardly any movement in the market. The low water level in the river Rhine was an unpredictable development, during which Mabanaft proved its strength. The traders reacted immediately by continuing to supply their customers while also achieving good margins. That's how our businesses complement each other: Oiltanking and Skytanking provide long-term stability, while Mabanaft gives us the flexibility to respond to short-term market developments. Like in boxing: Your stance has to be firm and stable to allow you to absorb your opponents' attacks, but you also have to be agile enough to counterpunch.

**Why has Marquard & Bahls withdrawn from some areas?
The holding company was downsized, too.**



Lorenz: Besides the financial situation of these businesses, the decisive factor for withdrawing from selected areas was the realization that we lack the expertise to successfully advance the business in these areas. We undoubtedly have it in our core businesses, but less so in emissions trading or biogas production. However, these companies definitely have a future.

Mark: Naturally, streamlining the holding company wasn't an easy step for us. In recent years, however, costs have risen dramatically, while the financial results did not grow accordingly. We had to cut our cost base – there was no other way.

A strong financial base has always been an important success factor for Marquard & Bahls. Does that still hold true today?

Lorenz: Absolutely yes. We have a well-adjusted balance sheet, are solidly financed, and possess the necessary resources, ideas and projects to continue growing. The top priority is to make our investment decisions in such a way that this remains the case going forward.

What areas do you plan to invest in?

Mark: Our focus in the further development of Marquard & Bahls is on energy and chemicals, markets in which we have the necessary management expertise. Take Oiltanking, for example: The company is increasingly concentrating on the gas and chemicals sectors. Mabanaft is also exploring new paths, e.g. by developing its own online trading platforms, while Skytanking is primarily pursuing geographical growth.



Lorenz: And even if we have withdrawn from the emissions and biogas business, sustainability remains an important value for us. Sustainability aspects will continue to play a decisive role in our investment strategy and in the development of new projects.

Mark: Of course there are opportunities for growth beyond our established paths as well. Energy efficiency is an interesting topic, as is the question of how energy can best be transported and stored. Water and some of the niche technologies could also be of interest, but this needs to be analyzed in more detail. One thing is certain: The energy mix will include oil, gas, sun, wind and more. We are monitoring how the energy markets are developing – and what role we can and want to play in this. Gas and chemicals will definitely be a topic.

We have a footprint on all continents except Australia. Mark, as a native of Australia, do you intend to change that?

Mark: Australia is a good market, so the folks there aren't exactly waiting for us to turn up.

Lorenz: Skytanking would probably have the best chances.

Mark: Yes, that's true ... and the idea of getting out of the plane in Melbourne and seeing Skytanking refuelling another plane has its charms, of course.



We're seeing a lot of positive developments. Is that enough to be successful in the future?

Mark: Marquard & Bahls is a strong company. Let's take a look at where we stand today: We've streamlined our portfolio, are focusing on our core businesses, which are healthy and solid, and are optimizing our processes where necessary. **Shaping Our Future**, the title of this Annual Report, is a very appropriate description of the current situation.

Lorenz: We are in a phase of transformation, which also involves the introduction of better process management. But that doesn't mean over-regulating everything and everyone down to the smallest detail. Quite the opposite!

Mark: The role of the holding company is to provide the best possible support for the divisions. Managing and developing their activities is the task of the companies and their management. Our managers will continue to have the entrepreneurial freedom to run their businesses.





**Your speeches are all about safety, sustainability and values.
How important is this to you?**

Mark: Very important! If a business isn't safe or ethical, or cannot be run in a safe or ethical way, we will not get involved in it. This includes the fact that our business actions are always based on our values. Respect, Accountability, Integrity, Responsibility – these values are important to us and we must live them, especially the management. As the maxim goes: "Lead by example not by exception."

Lorenz: The same is true for our corporate philosophy: independent, sound, reliable – this is Marquard & Bahls' identity, and it is how we conduct our business, today and in the future.

Where do you see Marquard & Bahls five years from now?

Mark: We will be active in the energy and chemicals sectors, and will continue to be involved in tank storage logistics, trading, and aviation fuelling. In addition, we will be active in new faster-growing markets.

Lorenz: We will have further developed our processes and increased profitability – and we will be a stable and agile company.

Mark Garrett
Chief Executive Officer

Lorenz Zwingmann
Chief Financial Officer



HOLDING

Trust in Our Strengths

The Marquard & Bahls Group had a challenging business year in 2018. While the core operating divisions achieved good results, unscheduled write-downs and restructuring expenditure in particular led to a Group net loss for the year. In view of the portfolio adjustments made, however, we are confident that we will soon make a return to positive figures.

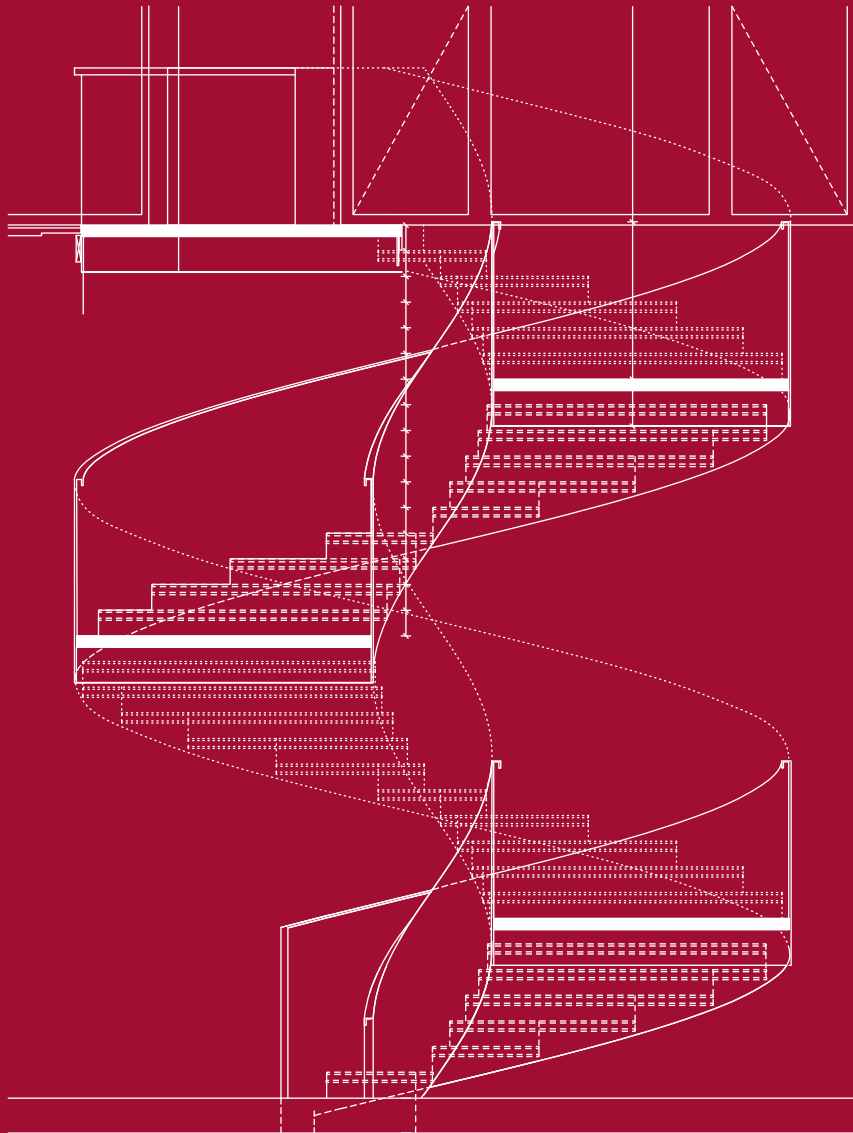

The year 2018 was marked by many changes, including a change in the Management Board. The unsatisfactory annual result was due in particular to unscheduled write-downs and restructuring expenditure in several areas: individual Oiltanking sites, and the companies Bomin and United Bulk Terminals.

Among the year's key decisions was the disposal of several of the Group's activities: In bunkering, sites were shut down or sold; emissions trading was divested; and the biogas activities were pooled in the IOT joint venture.

Apart from this, there are also many positive developments to report. All of the core operating divisions are doing well: Oiltanking continues to grow, especially in tank storage and the handling of gas and chemicals. Mabanft is very successful in the retail sector and is launching new trading activities in the U.S. Skytanking is expanding in several countries, and the holding company is optimizing its processes and seeing initial successes from this.

In 2019, the operational units – tank storage logistics, trading, and aviation fuelling – will be further strengthened. Costs will continue to be a focus. Another focus is on the company's values. To understand, internalize, and actively live them is a central task for employees and especially for the management. The aim is to significantly increase Group net income for the year, thereby simultaneously improving the return on equity.

We are confident that in 2019, we will be able to continue our successes in our core businesses and take decisive steps towards future growth.

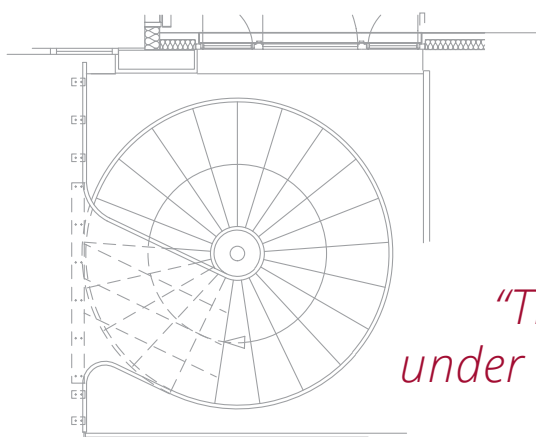

“The road to success is always under construction.”

Lily Tomlin



Our Strategic Approach

At Marquard & Bahls, we share a common set of values that guide our actions and behaviors. We are committed to treating one another with respect, acting with integrity, and accepting accountability and responsibility. This commitment is symbolized by our values, which form the pillars upon which our mission and our vision can firmly rest.

Our vision is to be the preferred partner in supply, trading and logistics of energy & chemicals. Our path to achieving this is clearly defined in our mission. We firmly believe that our philosophy – our independent, sound business practices and our reliability – provides a strong foundation for our long-term success.

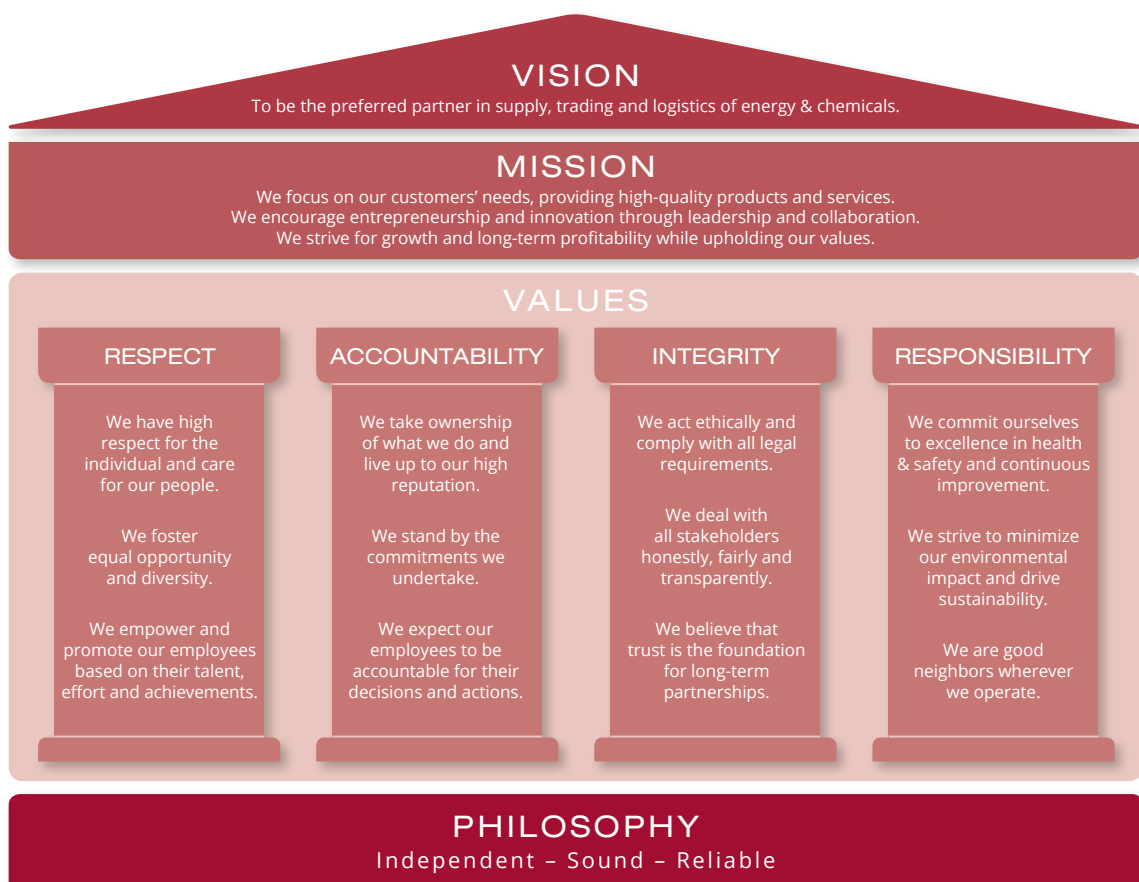

Marquard & Bahls



Renewal

The energy markets worldwide are in a state of upheaval. One of the most urgent tasks of our time is to meet the increasing demand while also reducing environmental pollution. New technologies are being used, and the energy mix is changing. Energy efficiency and the general question of how energy can best be transported and stored are other issues that concern us.

*How does **Marquard & Bahls** position itself in this environment? From our Group headquarters in Hamburg, we flexibly adjust our business models to be the preferred partner for*





our customers, now and in the future, in the areas of supply, trading and logistics for energy & chemicals. We will be expanding our portfolio to include new lines of business beyond our core businesses, which are tank terminal logistics, trading, aviation fuelling. Safety, reliability and sustainability will remain equally important regardless of this. And agility, because like the ever-changing markets, our company is also in a process of continuous renewal.



Employees

In 2018, Marquard & Bahls employed 7,561* people worldwide, in 36 countries. The number of employees has therefore changed only slightly vis-à-vis the previous year (7,727). In 2018, the Human Resources department continued to pursue the overriding goal of recruiting and promoting employees and optimizing internal processes. Key projects included the introduction of a new global HR management system. This application combines people and talent management, and meets the various requirements of managing a global and diversified workforce. It allows for harmonizing and standardizing our global HR processes. Our executives and the majority of our employees are already working with the new system, which is available in eleven languages and already includes many cross-functional e-learning programs.

Another HR project was the introduction of a new bonus system for managers, which takes into account the company's long-term performance. The coordination of the executive development program and the FUEL trainee program was once again incumbent on the HR department. In addition, it supported dual-track students and apprentices in their training. Here, too, increasing use was made of e-learning tools and web seminars.

There are many tasks ahead for Human Resources going forward: Besides the provision of resources and competencies in the form of qualified and motivated employees, the further support of the change process is of central importance.

Employees by region

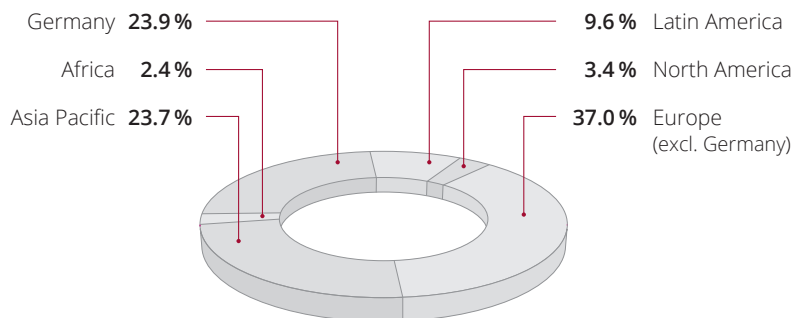

Employees by company

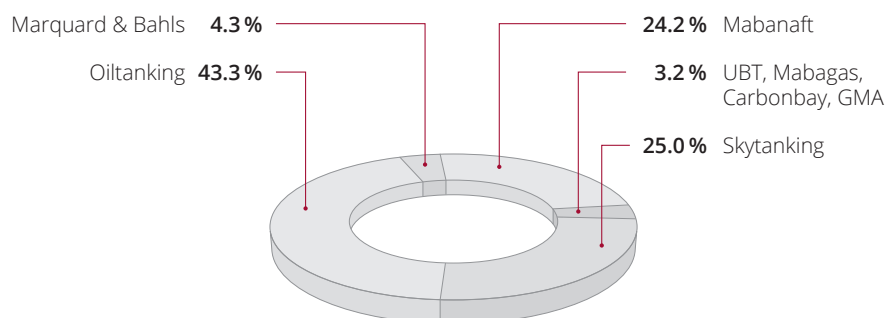

Total: **7,561**
December 31, 2018

* Including employees of all non-consolidated and associated companies at year-end. In 2018, an average of 5,340 people were employed in the Group's units.

HSSE – Health, Safety, Security and Environment

In 2018, three people lost their lives in accidents related to our activities. We deeply regret this. Our thoughts are with those affected and their relatives. One of the accidents occurred on the premises of Oiltanking MOGS Saldanha, South Africa, where a third-party worker was killed in the collapse of a reinforcing steel cage. Two more people died in traffic accidents in South Africa. In all cases, we have analyzed the causes of accidents in detail, critically examined the processes, and taken measures to avoid a recurrence.

We want to ensure that every one of our employees and everyone who works on our sites returns home safely every day. We only operate businesses that we can operate safely and ethically. It is our goal to continuously improve our safety standards through technical, organizational and behavioral measures. Safety first has the highest priority.

In 2018, we were once again able to improve our rates for product releases, fire, and material damages. With regard to injuries, we failed to achieve our targets, and we recorded an increase in the total number of injuries as well as the fatalities described above.

In March 2018, Oiltanking held its second Global Safety Day to further promote a culture of safety at its sites. Films, lectures, discussions and practical on-site drills helped build awareness for HSSE topics and train employees and contractors. The global survey on safety culture conducted in the course of the year showed an improvement over the 2014 results. In addition, a computer-based HSSE training for executives was developed, and a standard software program for root cause analysis (RCA) was rolled-out worldwide, accompanied by a training program.

At Skytanking, important content was added to the existing Learning Management System (LMS). The LMS makes it possible to organize and carry out the many HSSE training courses on site.

At Oiltanking and Skytanking, HSSE audit programs have been in place for many years. Since 2018, Marquard & Bahls' HSSE department has carried out audits at OIL! service stations and Petronord as well. In all, M&B HSSE performed 65 audits in 2018.

Company-wide dashboards were also introduced across the Group at the end of 2018. Based on the existing accident databases, the relevant statistics on all HSSE KPIs can now be retrieved worldwide, updated daily.

Ensuring health, safety, security and environmental protection will continue to be our top priority in the future. 2019 will see a focus on the further reduction of workplace accidents at all our companies.



Sustainability

Marquard & Bahls is committed to acting as a fair employer and a committed member of society. We assume responsibility by considering and internalizing the principles of sustainable management in all our activities. We see future viability and sustainability as inseparable topics.

In 2018, we increased our efforts in many areas, including social commitment. The total amount of donations & sponsorship increased by around 30 percent; many of our employees were involved with charities, and the hours of volunteer work increased again.

There are successes to report in the area of environmental protection as well: We participated in the annual Hamburg Climate Week with lectures and campaigns, which aroused great employee interest at the company headquarters. In addition, many energy-saving projects were again implemented at our sites. For example, the photovoltaic systems installed last year at our tank terminal in Malta on the roofs of the administration building can generate up to 192,000 kWh of energy annually. Meanwhile, Oiltanking rolled-out a detailed e-learning program on the subject of sustainability.

We have published the Group's progress and relevant indicators in our Sustainability Report, which follows the internationally recognized Sustainability Reporting Standards of the Global Reporting Initiative and the German Sustainability Code (DNK).

At the end of 2018, Marquard & Bahls once again supported a SOS Children's Villages facility with a corporate donation of 100,000 euros. The money went to a project in Tema, Ghana (West Africa). We feel a sense of commitment to the country, as our tank storage company Oiltanking operates two offshore transshipment moorings here, including the associated pipeline infrastructure, with a local partner since 2017.

The Group-wide sustainability strategy was further developed in 2018 and is to be implemented in 2019.



TANK STORAGE LOGISTICS

Oiltanking Delivers a Solid Performance

In 2018, Oiltanking achieved an operating result that exceeded expectations. This was achieved despite backwardation in the first half of the year, which put pressure on capacity utilization and rates in the global tank terminal market. Oiltanking successfully stood its ground: Many existing contracts were renewed and new projects advanced.

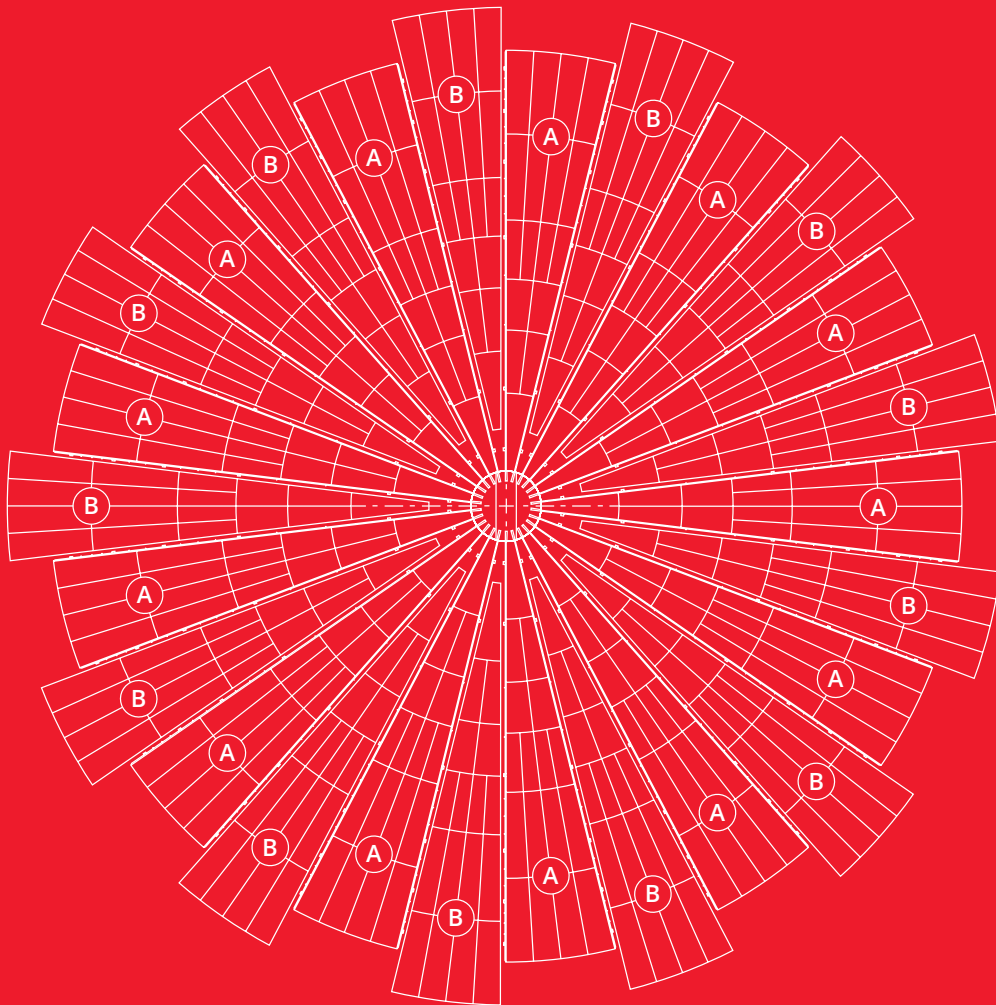

Competition intensified, especially in the hub regions of Singapore, ARA, and Houston, while the wave of refinery closures came to an end. Last year, the gas and chemicals markets once again offered opportunities for expanding the Oiltanking portfolio in line with its strategic direction. At the end of 2018, Oiltanking owned and operated 75 terminals in 24 countries, with a total storage capacity of more than 20 million cbm.

Europe

Continued backwardation, especially in the first half of the year, and growing competition led to declining tank capacity utilization. In addition, the diesel business suffered from the effects of the diesel scandal. On the other hand, chemical throughputs increased as did interest in storage capacities for cryogenic gas.

Germany

Oiltanking Deutschland closed the year with a positive result, despite declining throughputs from a major customer. However, an improved cost structure partially compensated for the corresponding decline in sales, so that the financial year ended with a profit, albeit below the previous year's level and below budget. Because the tank terminal network was nevertheless able to consolidate its market position, the outlook for 2019 is positive.

Hungary

Capacity utilization and throughputs at **Oiltanking Hungary** were in line with expectations, leading to a solid result. As all existing customers renewed their contracts, the tank terminal will operate at full capacity in 2019 as well.

Tank Capacity

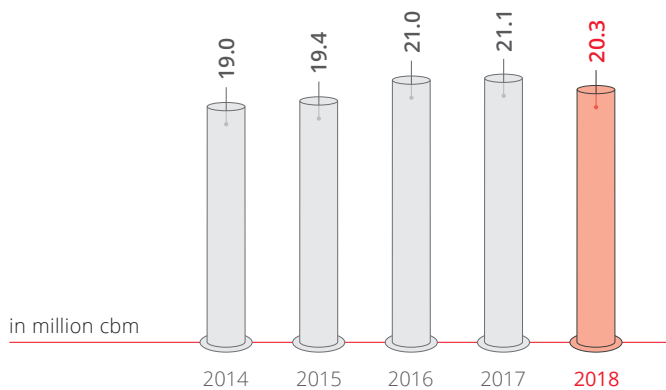

Belgium

Oiltanking Antwerp Gas Terminals exceeded expectations, mainly due to higher overall throughput. The construction of the 135,000 cbm butane tank is progressing according to plan and the approval process for the construction of another gas tank of the same size was successfully completed. It will store propylene and propane to supply a customer's dehydrogenation plant.

Despite the premature termination of a contract, results at **Oiltanking Stolthaven Antwerp** remained within budget – essentially because it was possible to find a replacement to utilize the storage space in question at short notice. In view of its good infrastructural connections and optimal location, the tank terminal is expecting continued good development.

Results at **Oiltanking Ghent**, on the other hand, fell slightly short of expectations. Capacity utilization declined in the first half of the year, and high cleaning and maintenance costs had an additional negative impact on earnings. Some of these costs were offset by cost-cutting initiatives and by increasing capacity utilization in the second half of the year.

Bulgaria

Oiltanking Bulgaria had a good year: An important contract was extended and a new contract concluded. As part of this contract, two tanks were converted and the fire-extinguishing system was modernized before going into operation in March 2019 and significantly expanding the tank terminal's portfolio.

The Netherlands

In 2018, **Oiltanking Amsterdam** further strengthened its position in the ARA region by concluding several new contracts. Among other things, the lucrative sale of a biodiesel plant on the site in the middle of the year led to a long-term agreement for the storage of biodiesel and its components, including associated blending services. The tank terminal will further expand its position in the fuel supply sector at Schiphol Airport by converting several tanks and building a new jetty. Commissioning of the new installations is scheduled for the third quarter of 2020.

Results at **Oiltanking Terneuzen** exceeded the budget thanks to high revenues from spot contracts and additional services. All other activities and capacity utilization remained stable and were therefore within the expectations.

Malta

Oiltanking Malta was not negatively affected by general market developments. This was also due to additional income from heat generation. Capacities were fully utilized throughout the year, leading to good overall results. However, increasing competition continues to put rates under strong pressure.



Nordics & Baltics

Russia's political and economic situation continued to have a decisive influence on the market environment of the Baltic region sites in 2018.

Denmark

Utilization rates at **Oiltanking Copenhagen** declined during the year. As a result, earnings remained under budget even though revenues from ancillary services were satisfactory.

The modernization of the neighboring tank terminal, which Oiltanking took over in 2016, is progressing well and its capacities have already been fully rented out. It is scheduled to go into operation in 2020.

Estonia

The ongoing transit blockade imposed by Russia on oil products continued to negatively impact capacity utilization at **Oiltanking Tallinn**. As a contract for the storage of bunker fuels also expired, revenues fell short of expectations, which means that the hoped-for financial turnaround is still not in sight.

Finland

Oiltanking Finland, with sites in Kotka and Hamina, benefited from rising product exports from Russia. Nevertheless, railcar filling capacity utilization remained difficult in the winter half of the year. An unforeseen payment for customs duties also had a significant negative impact on the result.

North America

In 2018, the upstream sector in the U.S. regained some of its momentum, which had a positive effect on the tank terminal sector. However, the market is adversely affected by the ongoing trade disputes.

USA

At **Oiltanking Galveston County**, higher-than-expected throughputs in the first full financial year led to good results.

Oiltanking Joliet also did better than expected, mainly due to the increasing number of tank truck fillings. The aim is to strengthen the tank terminal's market position by expanding the portfolio to niche products.

Throughputs at **Oiltanking Texas City**, on the other hand, remained below expectations. However, as new contracts for the storage of ethylbenzene have been concluded, the outlook for 2019 is positive.



Latin America

The unstable political and economic situation in some Latin American countries poses some major challenges for the sites. Nevertheless, this part of the world remains an important region in which Oiltanking has a strong presence.

Argentina

The aggressive depreciation of the local currency affected all sectors of the Argentine economy. And although the export-related sectors showed first signs of recovery, **Oiltanking Ebytem's** throughput was down. Due to an extensive cost management program, the results of the sites in Puerto Rosales and Brandsen nevertheless were well over budget.

Brazil

Oiltanking Terminais in Vitória achieved full capacity utilization with rising rates. In combination with the expansion of the spot business, this led to a result that exceeded expectations.

After dredging at the site was completed in early 2018, the expansion of the **Açu Petróleo** facility for ship-to-ship transshipment in the port of Açu continued. All approval processes were successfully completed in the course of the year, and the first VLCCs (Very Large Crude Carriers) were already handled.

As expected, the tank terminal for bunker oils operated by **Oiltanking Logística Brasil** under an O&M contract in the port of Açu developed positively overall. The site is currently negotiating with potential new customers in order to diversify its sources of income as broadly as possible.

*“One does not discover new continents
without having the courage
to lose sight of old coasts.”*

André Gide

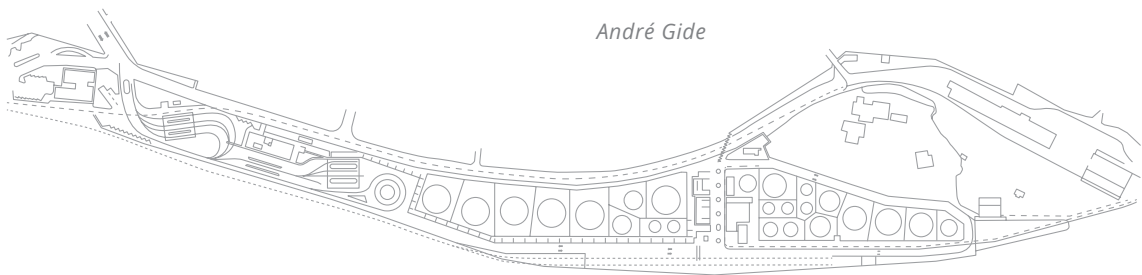

Oiltanking



Focused on Solutions

The global population is growing. As a result, demand for energy sources and chemicals, which play an important role in all of our lives, is also increasing. This dynamically changing environment affects the transport, storage and handling of these products as well.

Oiltanking has a broad portfolio of services in the tank storage and handling of petroleum products, gases and chemicals. As a competent and efficient partner, we are integrated into





the value chains of our customers. Our success results from our innovative strength and our ability to adapt to changing market requirements. One example of this is our involvement in the gas sector. In Antwerp, for example, we are currently building the world's largest butane tank with a capacity of 135,000 cbm. Further projects, particularly in the gas and chemicals sectors, are in the pipeline. We always focus on complying with the highest safety standards, and on thinking and acting in a solution-oriented way for our customers.



Colombia

Oiltanking Colombia's Cartagena site grew its throughput by 35 percent in 2018, mainly due to increased ethanol imports. In order to meet the continuing rise in demand, construction on the jetty expansion started at the beginning of 2019. In combination with the diversification of the product portfolio and long-term customer contracts, this will further improve results.

Due to the low water level of the Rio Magdalena, the throughputs of the tank terminal in **Puerto Bahia**, which Oiltanking Colombia operates under an O&M contract, declined in the first half of the year. Nevertheless, a positive result was achieved. As both the crude oil stock of the refinery located on this river and the number of ships increased again in the second half of the year, the outlook remains good.

Mexico

Construction on the two tank terminals that **Oiltanking Mexico** provides engineering services for progressed well in 2018. In Tuxpan, the shipping channels are currently being dredged and work is underway both on the tanks and on the expansion of the dock. Both sites are expected to be completed in the third quarter of 2019 and will subsequently be operated by Oiltanking Mexico on behalf of the owners.

Panama

Due to the difficult market environment, tank terminal utilization at **Colon Oil and Services** remained below expectations, while throughputs remained in line with expectations. However, the changes in the marine fuel market associated with the IMO 2020 Regulation offer opportunities in middle distillates storage that are currently being reviewed.

Throughput

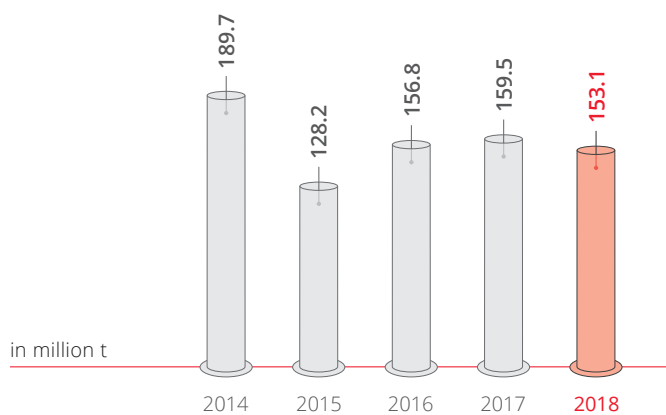

Peru

Oiltanking's **Terminales del Peru** and **Consortio Terminales** joint ventures ended the year 2018 with positive results. Consortio Terminales renewed its contract to operate five tank terminals in southern Peru by another year. To meet the rising demand for tank space, the Terminales del Peru facility in Callao commissioned two new tanks with a total capacity of 20,000 cbm in the third quarter. The results of the four sites in the north of the country, which Terminales del Peru also operates, were positive and above expectations.

Logistica de Quimicos del Sur, based in the port of Matarani, renewed a contract for the storage of sodium hydrosulfides for another year in May 2018.

It was also a satisfactory year for **Oiltanking Andina Services**, which operates the marine platform in Pisco.

Middle East and Africa

The business environment in the Middle East remained highly competitive in 2018 due to overcapacities, while in Africa the positive development of the fuel market offered new business opportunities.

United Arab Emirates

Star Energy Oiltanking managed to keep capacity utilization of the tank terminal in Jebel Ali, Dubai at a solid level in the first half of the year despite a sharp drop in demand. In order to be fully prepared when demand rises, the tank terminal carried out extensive maintenance during this period. From September onwards, the tank capacity was fully utilized once again. In addition, an agreement was concluded that makes the site the strategic tank space provider for Dubai's new airport.

Oman

Utilization at **Oiltanking Terminals** in Sohar, Oman remained at the previous year's level, albeit at lower rates. However, as throughput increased significantly, the overall result is well above budget. At the end of the year, an initiative to optimize the tank terminal was also concluded, which strengthens the site's market position by further improving its competitiveness.

South Africa

Progress was made on the construction of **Oiltanking MOGS Saldanha's** crude-oil tank terminal in 2018. The first three tanks are expected to be commissioned in the third quarter of 2019.

In the first half of 2018, utilization and throughput at **Oiltanking Grindrod Calulo** in Durban fell short of expectations, but picked up again in the second half.



Results at the tank terminal in Cape Town remained within budget. Additional capacities for vegetable oil are currently under construction and are scheduled to go into operation in mid-2019.

Mozambique

Following its commissioning, **Oiltanking Matola** was able to rent out all the available tank capacity due to the high demand for fuel in neighboring countries. However, towards the end of the year, several customers terminated their contracts. Although exports from the port decreased during the year due to changes in customs regulations, tank space requirements are expected to rise again in the course of 2019.

Ghana

The result of the two offshore transshipment moorings including pipeline infrastructure, which **Oiltanking Ghana Services** operates with a partner near Accra, Ghana, was higher than expected.

India

Due to a one-off provision in the EPC business and the termination of several O&M and BOOT contracts, the result at **IOT Infrastructure & Energy Services** fell short of expectations.

It was a mixed year for the **terminalling sector**. The contract for the Navghar site was renewed for another seven years, the longest contract period in the tank terminal's history. In addition, the site was able to win a new customer and is currently obtaining approvals to expand its tank capacities for Automatic Transmission Fluid (ATF). The tank terminal in Raipur is also planning to convert two tanks for the storage of ATF. The site in Paradip was fully utilized and recorded its highest pipeline and LPG throughput in 2018. Four O&M contracts with a major customer expired and were not renewed.

In the **EPC sector**, the Turkey project was technically completed in April 2018. Some additional changes requested by the customer are now being implemented before the IOT EPC division's last major project can be completed.

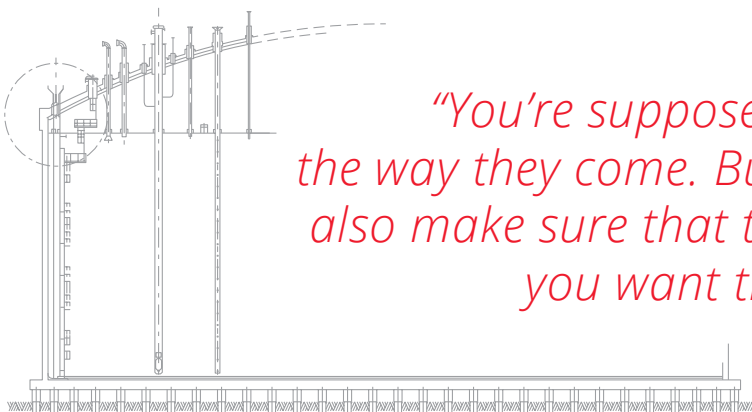

“You’re supposed to take things the way they come. But you should also make sure that things come the way you want them to.”

Curt Goetz

Asia Pacific

Overcapacity and strong competition put severe pressure on tank utilization and rates in this region as well. This effect was further intensified by the ongoing backwardation.

Singapore

Oiltanking Singapore result was below budget due to lower than anticipated occupancy of the heavy fuel oil capacity and lower storage rates because of the backwardated market situation.

The result at **Oiltanking Singapore Chemical Storage** was well above expectations, thanks to special effects as well as extending the useful life of the assets. The tank terminal successfully secured a project comprising two bullet tanks that will increase its capacity by 14,000 cbm.

The capacities of **Oiltanking Helios Singapore** were largely rented out for most of the year at lower than budgeted rates and therefore ended up below budget due to the difficult situation in the heavy fuel oil market. The tank terminal took advantage of its idle capacity to accelerate and essentially complete its ten-year tank inspection program. In December 2018, the two propylene bullets tanks with a capacity of 7,000 cbm each were successfully commissioned, on time and within budget.

The construction of the tank terminal of **Jurong Port Tank Terminals** progressed on schedule and within budget. It will have a total capacity of 232,000 cbm, four jetties, and pipeline connections to Jurong Island. The terminal will take up its operations in three stages. The first was completed in March 2019, the others are scheduled for June and October 2019.

Indonesia

For **Oiltanking Karimun**, 2018 was another difficult year due to backwardation, port charges, and customs restrictions related to imports. By the middle of the year, about two-thirds of its capacity was utilized, increasing to nearly full capacity by the end of the year. In spite of this positive occupancy rate, the terminal ended the year with a result under budget.

Oiltanking Nusantara Persada fell slightly below budget, as the anticipated expansion of the O&M agreement with a project management consultancy scope was deferred to 2019.



China

Lower throughputs and the conversion of several tanks caused results at **Oiltanking Daya Bay** to fall short of expectations. However, as utilization of the converted tanks has been rented out for the long term, the outlook is positive. Also, several long-term contracts were concluded under which new tanks are currently being built on an adjacent site. This capacity is planned to go into operation in 2020.

Results at the **Daya Bay Public Pipe Rack Company**, which operates pipelines in the Daya Bay Petrochemical Park, were above budget. The outlook remains positive due to the stable market environment.

Results at **Oiltanking Nanjing** exceeded expectations due to increased capacity utilization and additional revenues from ammonia throughput. The site signed a 15-year contract to build additional tank capacity and related pipelines to supply a customer's production facility. This contract includes the construction of one of the world's largest ammonia tanks.

Outlook

The market for energy and oil is still changing dramatically. The energy transition, the diesel scandal, digitalization, and impending trade conflicts are just some of the developments that are additionally having a strong impact in the tank terminal sector, along with the limitation on sulfur emissions from marine fuels, which comes into force in 2020 and will further change product flows even in 2019. Middle distillates are becoming increasingly important, and LNG could also become an important alternative fuel.

In addition, both the petrochemical and gas sectors are growing, and not just in North America and China. Despite the continuing growth in demand for fuels, tank storage will continue to change, partly as a result of increasing electromobility. With this in mind, Oiltanking will continue to add new segments to its portfolio and intensify its gas and chemicals activities. Beyond expanding its network and portfolio, however, providing customers with safe and reliable service will again be the top priority in 2019.



TRADING

Mabanaft Achieves Satisfactory Result

The Mabanaft Group had a satisfactory to good year in 2018. While the trading division improved its performance considerably after an initially difficult period and ended the year with a good result, the bunkering business was once again disappointing. Retail, on the other hand, continued its successful course.

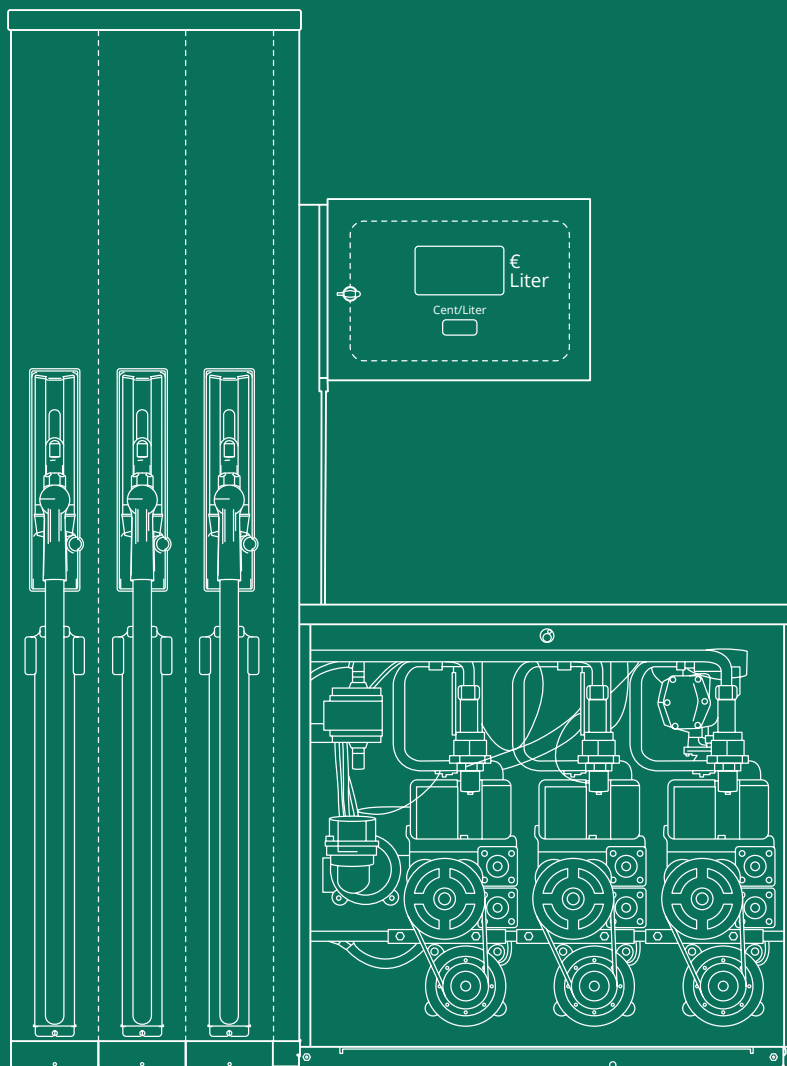

In 2018, the oil markets were again in backwardation for long periods of the year. There was strong demand for crude oil and petroleum products, from both industrialized and developing economies. At the same time, competitive pressure increased, and global political and economic uncertainties hampered the trading business in many places.

In this challenging market environment, Mabanaft Group's trading companies stood their ground with varying degrees of success: Mabanaft Trading experienced a strong third and fourth quarter after heavy losses in the first few months of the year. At Bomin, business remained disappointing in a still difficult shipping market, causing the company to withdraw from further locations. The situation was different in retail: Petronord and OIL! continued their successful course and delivered excellent results in their respective consumer markets. In total, the Mabanaft Group sold around 20 million tons of petroleum products and gas.

Mabanaft Trading

In 2018, Mabanaft operated with varying degrees of success in regional trading and wholesale in Europe, Asia, and North America. Good results were achieved in Germany, United Kingdom, and Hungary, while Singapore was less successful.

Germany

2018 was a turbulent year for **Mabanaft Deutschland**. After an unsatisfactory first few months, the situation began to change from the summer onwards: Margins increased significantly, so that the trading company ended the year with a very good result.

Sales

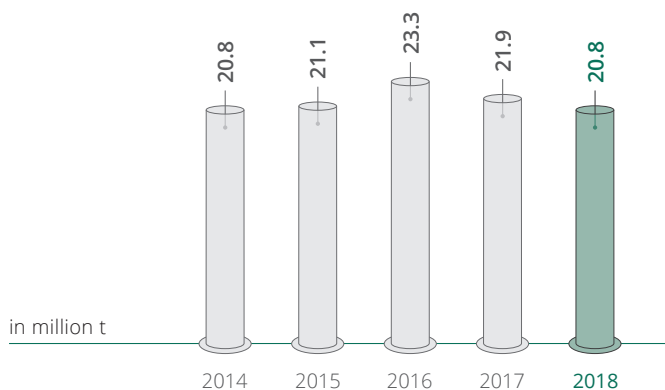

The market environment was characterized by strong competition, and extreme weather conditions. After a very dry spring and summer, water levels in the Rhine and other rivers were extremely low, which significantly impacted the supply of petroleum products. A temporary refinery outage in Bavaria further aggravated the situation. Things were particularly challenging in southern Germany. The German Petroleum Stockholding Association (EBV) released some of its stocks to ensure an adequate supply.

In this market, which was difficult for most of the year, Mabanaft Deutschland nevertheless reliably supplied its customers thanks to its good, forward-looking logistics management. Sales volumes were slightly below the previous year's level, while margins were very good, especially in the second half of the year. Only in Hanover was business down, as a previously very strong part of trading was discontinued. A lack of positive prospects for the business prompted Mabanaft to close the office in August 2018. By contrast, the other German sites were able to consolidate and expand their trading business. The heavy heating oil team based in Hamburg likewise made an excellent contribution to the result.

The year's positive developments included the planned implementation of the MabaLive trading platform. The first tests were successful, and the go-live was completed as planned in the first quarter of 2019.

In view of its good market positioning, optimized cost structure, and positive wholesale activities both in Germany and internationally, Mabanaft Deutschland expects a good business performance in 2019.

Singapore

The **Mabanaft Pte.** trading team in Singapore achieved further volume growth in a market characterized by strong demand. Nevertheless, in the face of fierce competition and low margins, trading proved challenging and 2018 ended with a negative result.

Key developments included the establishment of a warehouse and wholesale position in Mozambique in the spring and the integration of Gasoil's positions into the Global Book in the fall. Overall, the individual product groups ended the year with varying and ultimately unsatisfactory results. The closure of Bomin Singapore at the end of the year also resulted in the discontinuation of physical bunker oil trading.



Mabanaft Pte. anticipates the transformation of the trading landscape to continue in 2019. The introduction of the IMO 2020 regulation, the commissioning of a refinery in southern Malaysia, the effect of trade tariff conflicts (e.g. China and the U.S.) and sanctions (Iran) as well as trading companies' further consolidation activities will result in many changes. Mabanaft Pte. is pursuing further growth in this challenging but booming market.

USA

In July 2018, the newly established company **Mabanaft Energy Trading Inc.** took up its trading activities in Houston, Texas. The company was founded with the aim of promoting trade in middle distillates in the American markets.

The U.S. is the world's largest oil producer and one of the central hubs of international trade in crude oil and petroleum products, making it an accordingly attractive market for Mabanaft.

In the first few months of its activity, the trading team focused on setting up contacts and doing initial business. As expected, the results were still at a low level, but its further development looks positive.

United Kingdom

London-based **Mabanaft Ltd.** laid the foundations for future developments in 2018. Besides expanding the business, it also implemented a number of cost savings. In a difficult market with extremely low margins, the company achieved a good result at year-end.

Having already recorded strong volume growth in the jet fuel segment in the previous year, the company systematically advanced the expansion of this segment. For instance, Mabanaft Ltd. signed a long-term contract with a tank terminal at the Thames, which covers the storage of jet fuel and construction of a new truck loading facility for

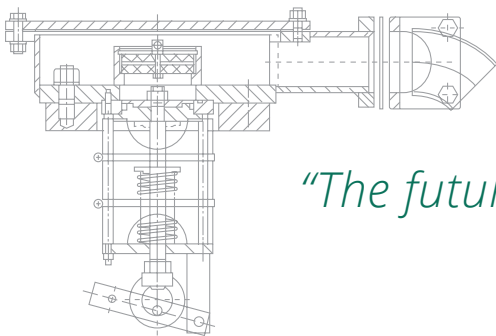

*"The future depends on
what we do in present."*

Mahatma Gandhi



Mabanaft's exclusive use. This also gives the company access to pipelines. In addition to nine airports in the U.K., Mabanaft Ltd. has also supplied Valletta airport in Malta since early 2018. At London Gatwick airport, three new jet fuel supply contracts were concluded.

In retail, new trading agreements were concluded with two large companies. Further opportunities to expand the consumer sector and possibly also enter the bitumen sales business are being reviewed. The sales volumes generated via the company's own online portal expanded. Compared with the very positive previous year, however, the performance of the OnRoute fuel card business was unsatisfactory.

Mabanaft Ltd. is optimistic for 2019. The main focus will be on jet fuel trading and the opportunities offered by biofuels. It remains to be seen to what extent Britain's imminent withdrawal from the European Union will have an impact.

The Weston-super-Mare-based trading company **B.W.O.C.** further expanded its market share in 2018 in a highly competitive environment. Margins improved and had a positive impact on earnings. The result was once again well above the already good performance of the previous year and significantly above budget.

The relatively young LYNX Fuels brand continued to establish itself and was profitable in 2018. The fuel card business also performed well, with stable sales and further expansion. The same applies to the bulk sales trade, which grew both its volume and profitability.

B.W.O.C. expects continued market volatility. However, the company has a flexible setup and will try to profit from the opportunities that present themselves with increasing sales volumes and good margins. Its future development will also depend on the impact that Brexit has on the economy.

Hungary

Budapest-based **Mabanaft Hungary** ended 2018 with a good result. The growth of the Hungarian economy had a positive impact, while currency effects had some negative effects.

Sales volumes increased again over the already-good previous year, although margins were increasingly under pressure. Tank truck imports as an additional supply channel continued to stabilize.



Mabanaft Hungary was also able to expand its service-station business. The network currently comprises 48 stations operating as franchises under the OIL! brand. In addition, the company invested in setting up its own network, which now comprises four service stations. As most of the Hungarian oil market is dominated by a single competitor, Mabanaft Hungary's consistently positive development is a remarkable success.

Its further development looks to be positive as well. The aim is to further expand sales volumes as well as the OIL! service-station network. New customers and franchise partners are to be attracted and OIL! marketing activities further intensified.

Moldova

In 2018, **Mabanaft Moldova** continued to supply other trading companies – including its sister company Tirez Petrol – with petroleum products. As in previous years, the trading business was burdened by the continuing economic and political instability, and results were not in line with expectations. The company's trading business was therefore discontinued at year-end. Mabanaft Moldova has since operated as a pure financial holding company for Tirez Petrol's activities.

Mabanaft Retail

Mabanaft operates in the end-consumer sector through its subsidiaries Petronord, Thomas Silvey, OIL! Tankstellen and Tirez Petrol. Nearly all of the companies had another strong business year in 2018.

End-consumer business

Germany

The **Petronord Group** once again achieved a very good result in 2018. At year-end, a total of 33 associated companies operated under the Petronord umbrella. The main focus of its activities is the private and commercial retail business with energy products, including the operation of filling stations for the commercial transport business.

While the heating oil business generated satisfactory margins and met expectations, lubricant sales faced a difficult market environment. In Bremen, TOTAL Mineralöl and Mühlenbruch Stinnes founded Mühlenbruch Stinnes TOTAL GmbH, a joint venture to pool their heating oil businesses. The approximately 240 pool stations achieved high sales volumes with adequate margins, and the bitumen business generated very good sales again. In 2019 Petronord will pursue further organic growth in all areas.



Austria

The Petronord companies operating in the heating oil and lubricants trade in Austria achieved good results in 2018. For 2019, the outlook is similar.

Sweden

In 2018, Petronord acquired a stake in Ltd. Stockholms Diesel & Oljehandel AB in Sweden. As a result, Petronord is now represented in Sweden by three companies and will continue to pursue its goal of further expanding its trading activities there.

United Kingdom

The trading company **Thomas Silvey**, based in Bristol, in the U.K., ended 2018 with an excellent result well above budget.

Its two key areas – bulk sales trading and the fuel-card business – continued to develop at a high level. In an intensely competitive environment and in view of the uncertainty due to the pending Brexit, the long-established company is very satisfied with this business development. Going forward, Thomas Silvey aims to continue its profitable growth, among other things by increasing efficiency and offering new services.

Service Stations

OIL! Tankstellen had another successful year in 2018. Profitability was lastingly increased with several consolidation measures in the service-station network, which at year-end comprised a total of 332 stations in Germany, Austria, Switzerland, and Denmark.

*“Success is not final;
failure is not fatal: It is the courage
to continue that counts.”*

Winston S. Churchill



Mabanaft Retail



Moving forward

What energy sources will Mabanaft trade in the future, and what technologies will we use? There are many variables at play that are continuously changing our trading business.

*At **Mabanaft**, we will continue to develop our business with a strong focus on markets and customers. One focus is on the retail segment, where we intend to continue to grow organically. The international trading business, which we manage mainly from Hamburg, Singapore*





and Houston, will also remain a central pillar of our business. Besides petroleum trading, we see good growth opportunities particularly in the gas business and in the expansion of lucrative niches. Digitalization also plays an important role: from the use of our own online platforms that already exist today to future models that will link our IT systems with those of our customers. As we move into the future, our trading activities will remain flexible, fast and reliable.



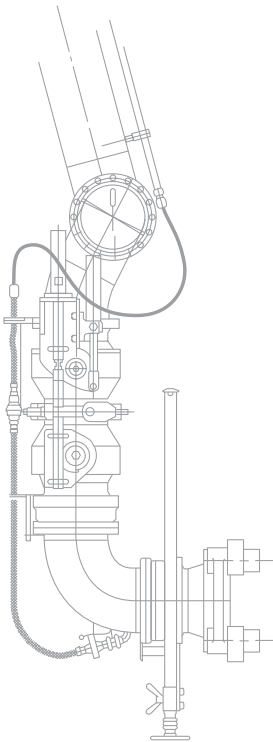

„It doesn't make sense to hire smart people and tell them what to do; we hire smart people so they can tell us what to do.“

Steve Jobs

Germany

OIL! Tankstellen's business in Germany developed very well. This applied both to fuel sales and the shop business. The further development of its brand design and the revised shop concept strengthened OIL!'s positioning in a keenly fought market. Seven service stations were converted to the new look in 2018, and around 50 further stations are to follow by the end of 2019. The budget target was significantly exceeded, due in part to strict cost management. OIL! considers itself well-prepared for future challenges and is striving for further growth.

Austria

In Austria, with the opening of a new service station near the A1 motorway near Vienna, the new OIL! brand identity was also introduced with very good customer feedback. The company clearly exceeded its targets and had one of its best years in recent history. The signs for 2019 are positive as well. A new fuel, Premium Diesel, was introduced in February, and will ensure a further increase in volumes.

Switzerland

In Switzerland, OIL! ended the year with a record result. Good margins, optimized delivery conditions, and stable sales resulted in a positive business performance. OIL! is optimistic for 2019 as well.

Denmark

The service-station network in Denmark grew by five stations and now comprises a total of 54 automatic service stations. Sales volumes increased accordingly, so that the budget was achieved. The company was also successful in developing collaborations with other brands, and will continue to pursue this path in 2019.



Moldova

In an economically and politically unstable environment, the Moldovan service-station organization **Tirex Petrol** achieved a good result due to positive one-off effects.

However, the company's future development is still seen as challenging. The company hopes that the situation will stabilize and provide greater planning security.

Bunkering

In 2018, the international shipping industry faced a situation that continued difficult, characterized by fierce competition and extremely low margins. The preparations for the IMO 2020 regulation, which stipulates a global reduction of sulfur content in marine fuels to 0.5 percent starting in 2020, are currently aggravating the situation for many market participants.

In this challenging environment, **Bomin** continued to consolidate its business. The company withdrew from Singapore, Antwerp, and Mauritius. The Dubai office was also closed. This means that Bomin is currently represented only in Houston and Hamburg. All existing customers in the German ports, on the U.S. Gulf Coast, in Panama, Norfolk, and Ecuador are supplied from these two locations. This significant downscaling is designed to help the company remain viable into the future.

Germany

The European bunker market, which **Bomin Deutschland** manages from Hamburg, was characterized by strong competition and aggressive pricing strategies in 2018. Despite all its efforts, Bomin ended the year with a disappointing result.

In order to focus its business more going forward, Bomin sold its Antwerp operations to a Belgian tank shipping line in the fall.

Bomin Deutschland aims to stabilize its business in 2019.

*"You can understand life backwards,
but you have to live it forwards."*

Søren Kierkegaard

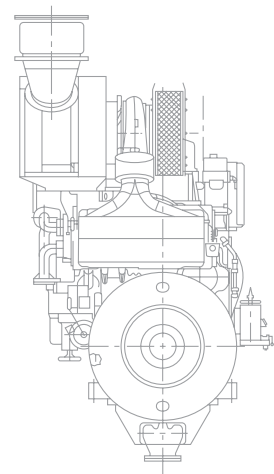

USA

Houston-based **Bomin Bunker Oil** team ended the year with a positive operating result in a highly competitive market. However, due to the creation of provisions, the overall result was negative.

For 2019, Bomin Bunker Oil is confident that it will benefit from opportunities in offshore bunkering off the U.S. gulf coast and further expand its activities in Central and Latin America. With a view to the IMO 2020 regulation, the blending options that Bomin can draw on at the Oiltanking Texas City tank terminal, are an advantage.

Outlook

The global oil markets will continue to be characterized by strong demand in future. Even as other energy sources are tending towards increasing their share of the energy mix, petroleum products will continue to make a crucial contribution to global energy supply. It is becoming apparent that developments in key export countries such as Saudi Arabia, as well as trade sanctions against Iran, Russia, and Venezuela, will result in increasing geopolitical instability.

In this challenging market environment, Mabanaft will remain a strong player in the years ahead. One focus is on retail, where the company is pursuing further organic growth. In bunkering, efforts are being made to stabilize the business. The international trading business, on the other hand, will continue to be a focus of trading activities in future. Mabanaft sees good growth opportunities in gas trading and in the expansion of lucrative niche businesses.



AVIATION FUELLING

Skytanking Records Further Growth

Skytanking looks back on a good business year 2018. Nearly all the sites reported growth in throughput volumes and the number of fuellings. The company also expanded its activities in Turkey and India, and laid the foundations for starting up operations in Spain and the U.S. in 2019.

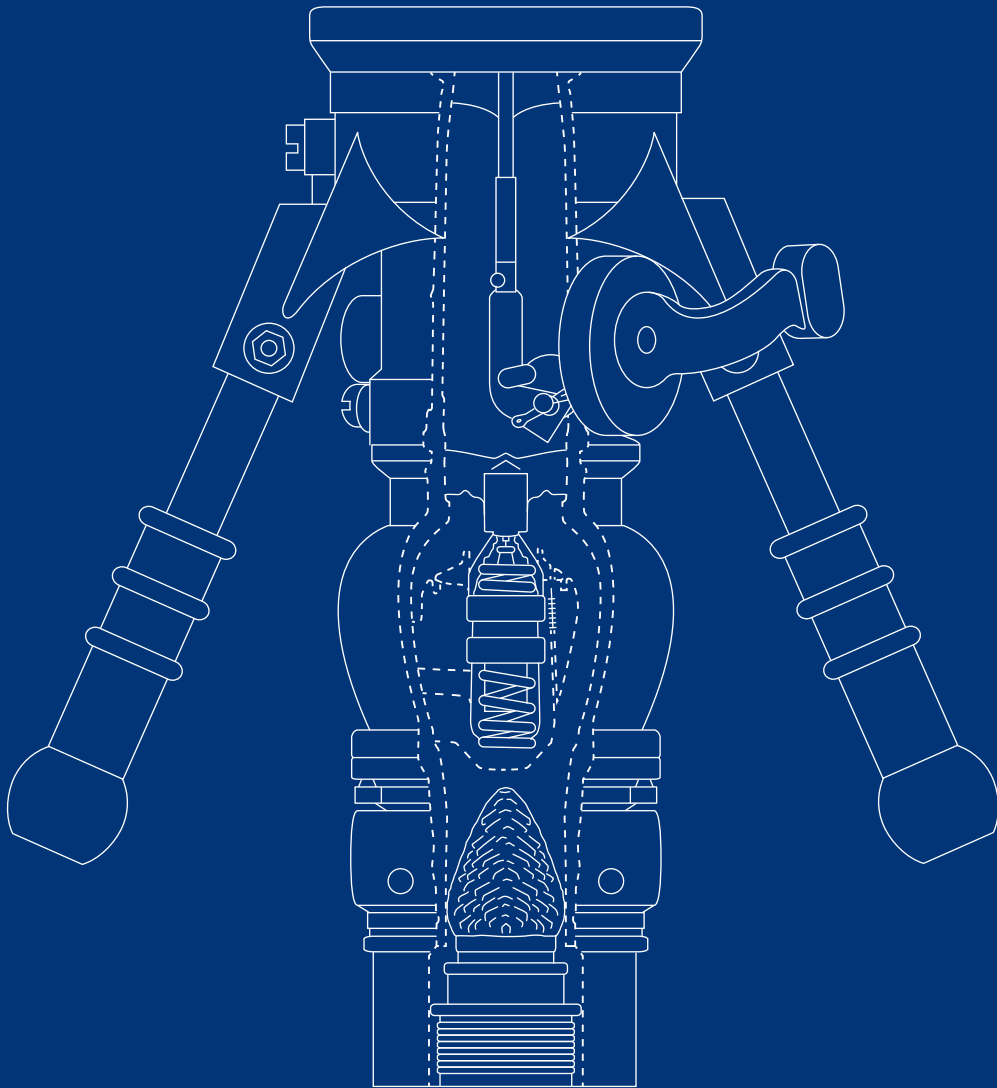

Despite higher jet fuel prices and increasing costs, the aviation industry recorded continued growth in the number of flights and passengers as well as in freight volume in 2018. A record 4.1 billion passengers were served worldwide, about seven percent more than in the previous year. The Asia-Pacific region saw the strongest growth with around ten percent, followed by Europe and North America with around four and three percent, respectively.

Skytanking benefited from the good conditions in many locations. Existing contracts were renewed, new agreements concluded, and new locations added to the network. At the end of 2018, Skytanking had operations at 75 airports worldwide. In the course of the year, the company refuelled two million aircraft (25 percent increase) and handled 23 million cbm (30 percent increase) of jet fuel.

Europe

Germany, Switzerland, Austria

The GSA region experienced healthy growth for the third consecutive year, further increasing its throughput volume, number of fuellings, and results.

Sunjet, which was acquired in autumn 2017 with its operations in Cologne, Dusseldorf, and Frankfurt, was successfully integrated into the network and made a positive profit contribution. All sites achieved good results with the exception of Hamburg, where competition remains fierce.

The sites in Austria and Switzerland – Vienna, Linz, Klagenfurt and Zurich – had another successful year, reporting increased throughput volumes and good results.

Skytanking expects the good performance to continue in 2019, as the new customers are expected to continue entrusting their business to the company.

Throughput

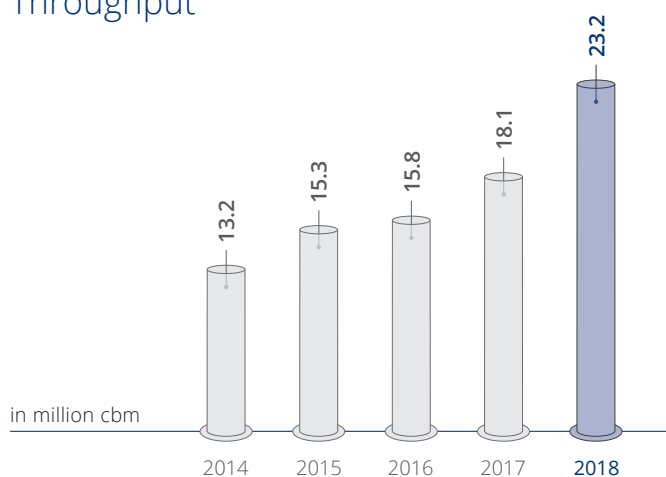

Belgium

At Brussels Airport, a central hub for international air traffic, Skytanking saw another year of growth despite increasing competition.

Both subsidiaries – **Skytanking NV**, which offers into-plane services, and **Hydrant Refuelling System NV**, which operates the on-site tank terminal and hydrant system, delivered good profit contributions. The outlook for 2019 is similarly good.

Luxembourg

Skytanking is represented at Luxembourg Airport, a growing cargo handling hub in Europe, with Luxfuel SA, a company in which it owns a 30-percent stake. **Luxfuel SA** is active in into-plane services as well as tank terminal operations, and had a satisfactory year in 2018.

A similar performance is expected for 2019. However, it remains to be seen to what extent the renovation work on the airport's runway, scheduled to last three years, will affect business.

France

In France, **Skytanking NV** currently has operations at just one location, i.e. Paris-Charles-de-Gaulle airport. The traffic volume at this major European hub increased slightly in 2018, which had a positive impact on Skytanking's result.

The operating contract has been successfully renewed, so that Skytanking will continue to operate at this airport for the foreseeable future. In 2019, Skytanking aims to expand its footprint in France.

Spain

In autumn 2018, Skytanking obtained the licenses required for providing into-plane services in Spain, the third-largest market in Europe.

Skytanking Spain S.L.U. is scheduled to start operations at Barcelona and Valencia airports in Spring 2019. Malaga and Palma de Mallorca will follow later in the year.

Italy

Fierce competition and high pressure on margins are presenting ever greater challenges for the **Skytanking S.R.L.** operations in Rome-Fiumicino, Naples, Palermo and Venice. Given these difficult conditions, the year-end result was disappointing despite an increase in passenger traffic.

Skytanking will continue its restructuring measures in 2019, to both restore its competitiveness and be prepared for future challenges.



Skytanking

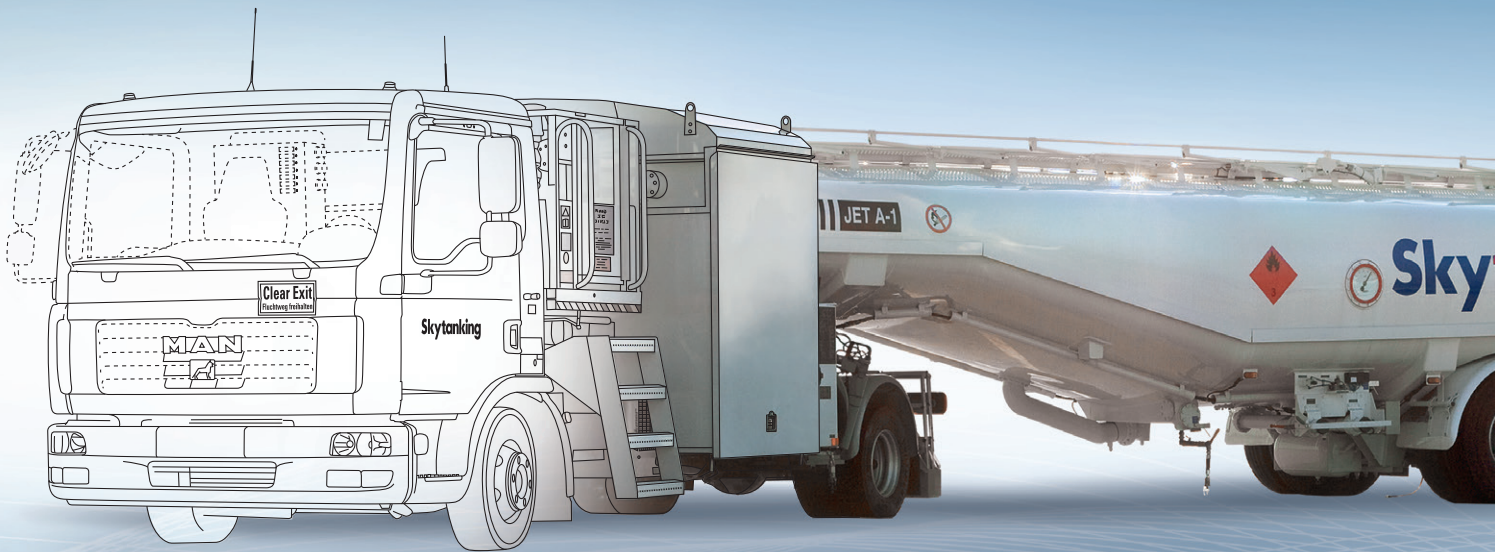

Unlimited

The aviation industry is the fastest-growing mode of transport in the world. Passenger and freight volumes are increasing rapidly from year to year. This is accompanied by changes in the requirements placed on aircraft and fuels, as well as airport processes, and thus requires a constant evolution of our business.

*At **Skytanking**, we concentrate on refuelling aircraft and operating airport tank terminals and hydrant systems. We will continue along the growth path we have embarked on, and*





High Service Quality



Safety first

Geographic growth

Engineering expertise

BOOT:
Build, Own, Operate, Transfer

Digitalization

Focus on People

continually add new locations to our global network. All our employees – fuelling operator, HSSE coordinator, engineers, administrators, managers – use their expertise to ensure that we work safely, reliably and efficiently around the globe. We are always aware of the ramifications of our actions. Safety first! is our top priority. Likewise, in matters of customer and service orientation, we strive to never stand still, but always keep improving.



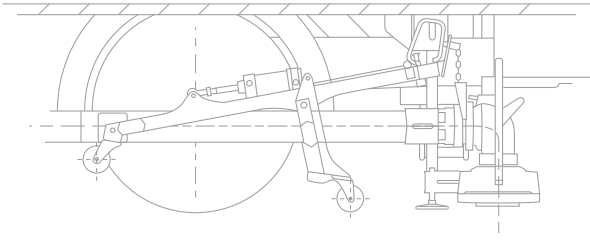

"If you want something new, you have to stop doing something old."

Peter Drucker

Malta

Skytanking Limited continued to face strong competition at Malta Airport. However, the company delivered a good performance overall, and ended the year with a satisfactory result.

The company expects to further stabilize and expand its business in 2019.

United Kingdom

The joint venture **North Air**, one of the country's market leaders and currently operating at 19 airports, benefited from rising passenger numbers in the U.K., accompanied by higher throughput. This led to an excellent result.

With a significantly increased vehicle fleet and a strong market position, the company is well positioned for further growth. The impact of the upcoming Brexit remains unclear.

Turkey

The **Skytanking Ovenon** joint venture in Turkey had a good year in 2018, clearly exceeding its budget targets and increasing its revenues nearly five-fold year-on-year.

In May 2018, the company started into-plane services at 20 airports in Turkey.

Turkey will remain a strong market in 2019, and Skytanking Ovenon has plans to further expand its business there. As soon as the new airport in Istanbul goes into operation, the company aim to provide aviation fuelling services there as well.

South Africa

Skytanking Calulo's throughput volumes at King Shaka International Airport in Durban, South Africa were down from the previous year, and the company ended the year 2018 with a result that was only slightly positive.

A new contract only partially offset the decline caused by discontinued flights.

Durban will remain a challenging location, and expansion of Skytanking's activities in South Africa is required to secure a successful business.



India

The Indian subcontinent is one of the fastest-growing aviation markets in the world, and **IndianOil Skytanking (IOSL)** has positioned itself strongly in this exciting market. The result was positive and well above target.

At the beginning of 2018, the company was represented at ten locations. By the end of the year, three sites were added in Puducherry/Pondicherry, Kadapa, and Bhubaneswar.

India will remain a promising market in which IOSL intends to expand further. At the beginning of January 2019, Pune Airport in West India, was added as the 14th location. Further additions are planned.

Outlook

In view of rising population numbers and increasing mobility, air traffic volumes are expected to continue to rise in the years ahead. However, geopolitical crises and trade disputes that are not predictable could have a negative impact. Nevertheless, the International Air Transport Association (IATA) forecasts that the number of air passengers will double from around 4.1 billion today to 8.2 billion in 2037.

In this promising, albeit competitive market, Skytanking aims to generate further growth through new contracts at existing sites, as well as through acquisitions and joint ventures. As part of its growth strategy, the company will expand its global presence by re-entering the USA. Atlanta, the first U.S. location, started operations at the beginning of 2019; further airports are to follow.

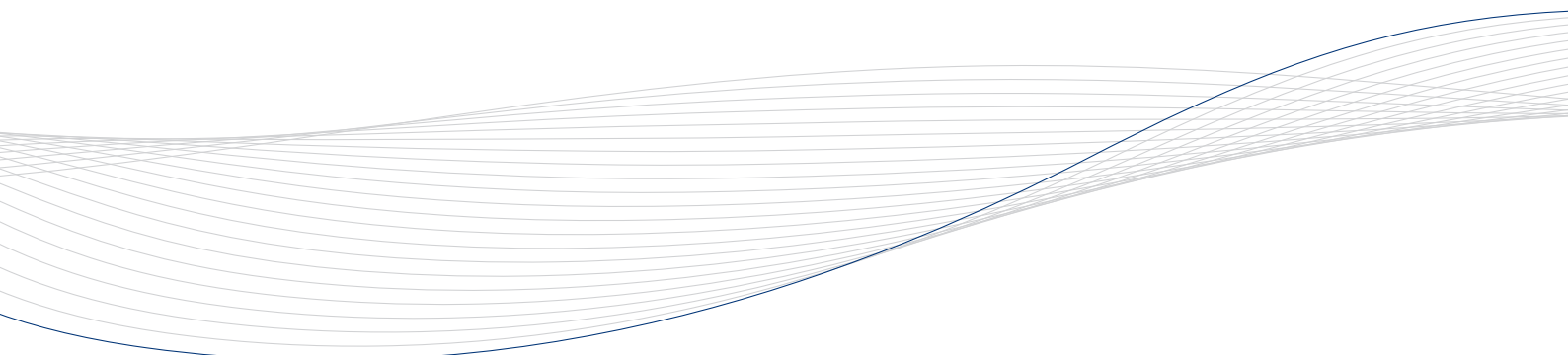

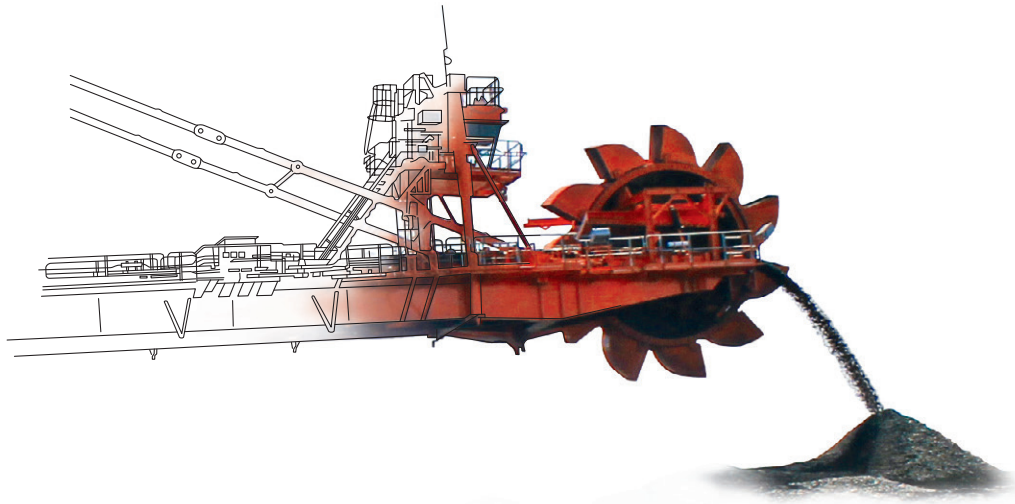

UBT's Performance Remains Unsatisfactory

In 2018, the U.S. coal market recovered and export volumes rose sharply. This had a positive effect on the business activities of the two United Bulk Terminals (UBT) sites in Davant and Corpus Christi as well. Nevertheless, the result remained negative.

UBT Davant was able to win three coal companies and a major petcoke producer as clients. Throughput increased to around five million tons. The new option of loading seagoing vessels directly from barges increased the dry-bulk storage facility's unloading speed to a record level. The deep-water docks, where the world's largest dry-bulk ships can be handled, also strengthened the site's position. It also managed to significantly reduce operating costs per ton. Nevertheless, sales figures remained disappointing due to lower petcoke production and increased freight costs to Asia. UBT Dupré in Corpus Christi met expectations and existing contracts were renewed for a further two years until the end of 2020.

The positive trend in the coal market seems to be continuing, so a further increase in throughput volumes is expected for 2019. The new contracts in Davant will also develop their full potential after the first full twelve months.



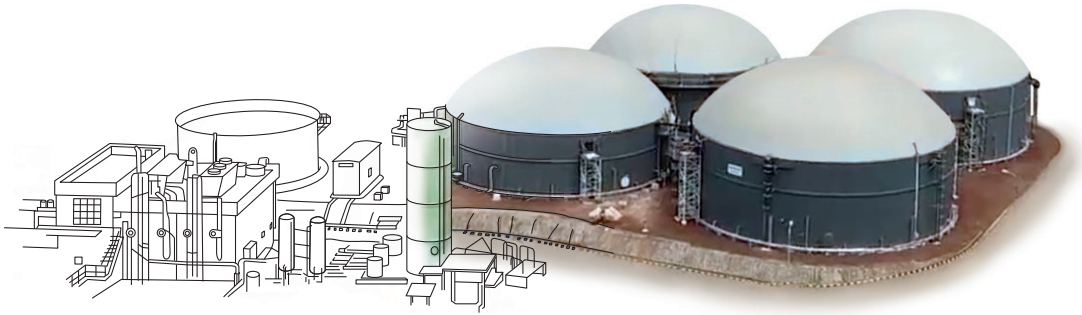

Mabagas Activities Integrated into IOT

The Mabagas biogas plant in India has been in operation since end of 2012. Since then, the company has continuously increased its electricity production and successfully established its own organic fertilizer brand. In 2018, both electricity production and fertilizer production increased, leading to a positive result.

In recent years, the company's portfolio has been steadily downsized due to the negative development of the German market. After the company had already withdrawn from biogas production in Germany at the end of 2015 and sold its CNG (Compressed Natural Gas) service stations in summer 2018, Mabagas latterly only operated the biogas plant in Namakkal, southern India.

As part of the realignment of the Marquard & Bahls Group, it was decided to operate this biogas plant under the umbrella of IOT Infrastructure & Energy Services from 2019.





Carbonbay Sold

In recent years, Carbonbay had developed a global portfolio of wind, hydro, biomass and solar power projects to help climate change. The projects managed by the company generated around 170,000 emissions certificates last year, which were sold above the market price, enabling Carbonbay to achieve its expected operating result.

This is a welcome development in view of the fact that the rather small market for voluntary carbon offsetting remained unregulated and highly competitive in 2018. Following successful certification, the initial distribution of certificates from the Guacamaya hydro-power program took place in June 2018. In addition, the company also offered its clients sustainability consulting services for the first time.

As Marquard & Bahls will concentrate on its core activities of tank storage logistics, trading, and aviation fuelling in future as part of its overall strategy, Carbonbay was sold with effect from the end of December 2018. Its current managing director, who has worked for the company since January 2015, will continue to head the company.





GMA Achieves a Good Result

Gesellschaft für Mineralöl-Analytik und Qualitätsmanagement (GMA) continued its stable performance in 2018 and achieved a good annual result.

As expected, business at both the fuel analysis testing laboratory in Frankfurt and the quality management and consulting unit in Hamburg was good. During the course of the year, thousands of samples were analyzed for sister companies and external clients. Sales of fuel additives also remained stable in a difficult market environment.

As in previous years, GMA participated in national and international standardization committees and helped further develop product standards and lab-testing procedures. In addition, it hosted various training activities on fuels and combustibles, and gave lectures on current topics in the petroleum industry.

GMA expects its business to remain stable in 2019.



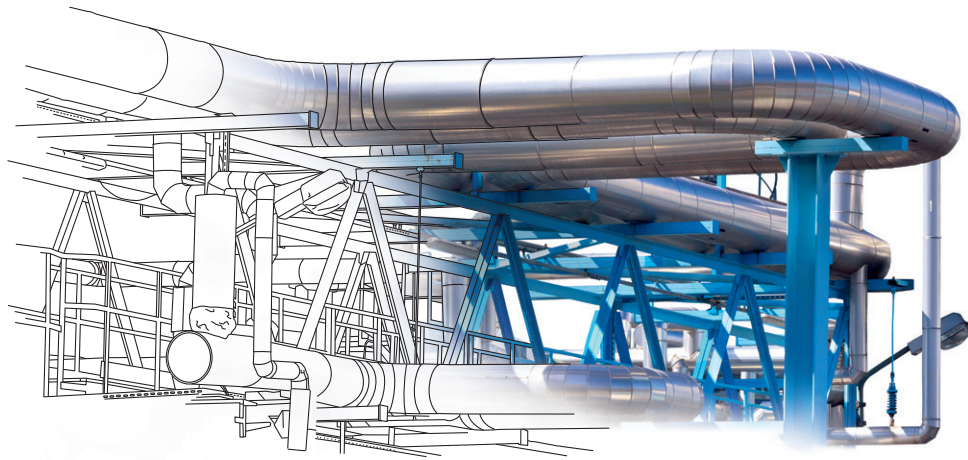

natGAS Further Expands its Business

natGAS is an independent international energy provider that supports major industrial customers, municipal utility companies, and distributors with energy solutions. In 2018, it matched its gas sales volumes of the previous years and further expanded its electricity business.

natGAS focuses on energy supply and the development of energy concepts to optimally support energy logistics in its customers' value chains. For example, it offers short-term day-ahead and intraday market prices for optimum management of gas and electricity consumption. Another alternative is price-optimized electricity generation from natural gas via "virtual power plants".

Last year natGAS also further expanded its portfolio of renewable energies. In addition, its portfolio in the direct marketing of renewable electricity from wind and solar power plants continues to grow rapidly.

In 2018, natGAS supplied its customers with approximately 140 TWh of natural gas (equivalent to 11.8 million tons of gasoil) and about 13 TWh of electricity (equivalent to 1.1 million tons of gasoil). The company will be pursuing further growth in 2019.



Active around the Globe



Sites Worldwide



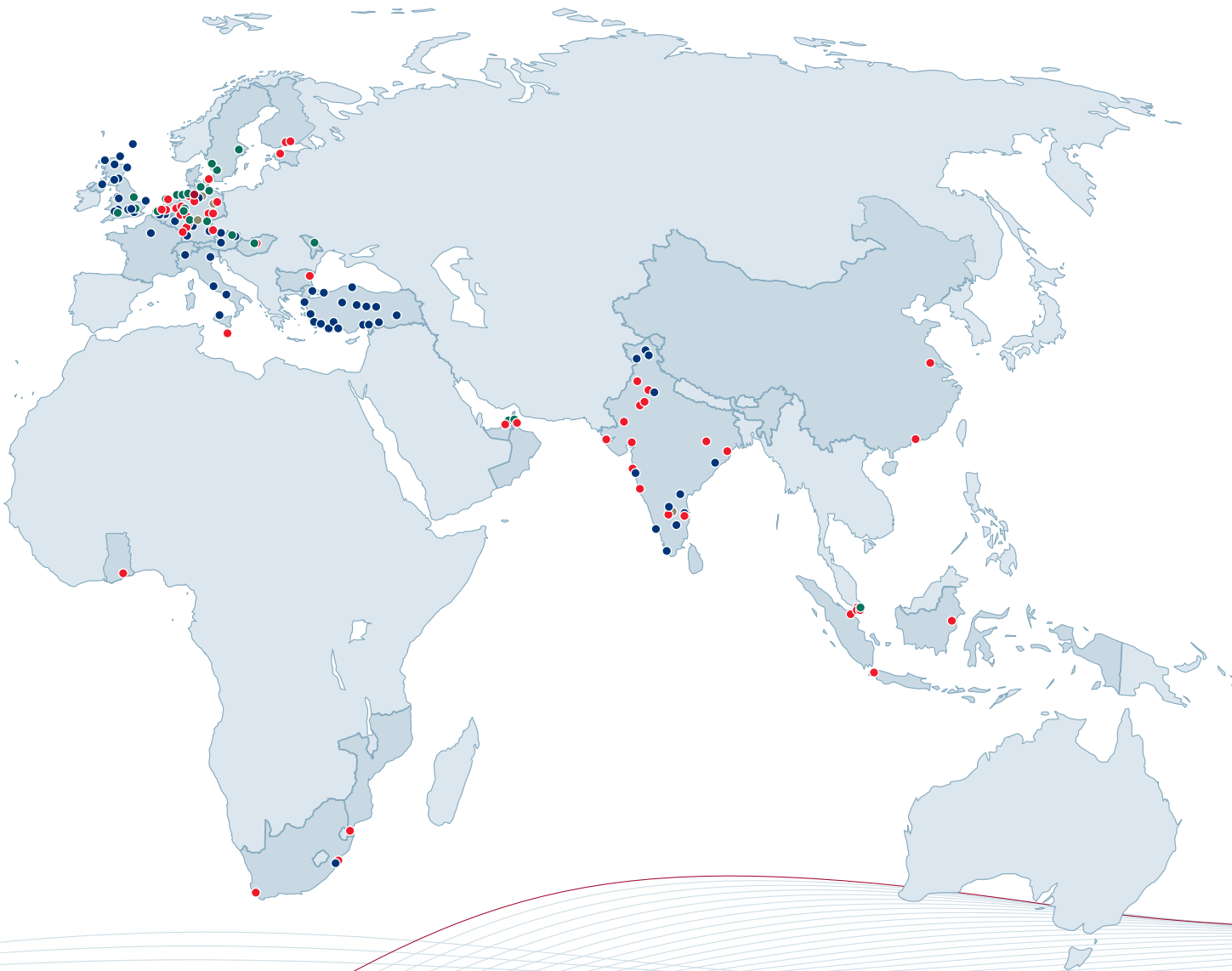

- Marquard & Bahls
- Oiltanking
- Mabanaft
- Skytanking
- UBT
- Other

As of: December 31, 2018



Report of the Supervisory Board

During the 2018 financial year, the Supervisory Board was informed regularly by the Executive Board both in writing and orally about the state and development of the company, the Group companies, and their shareholdings. The Supervisory Board discussed all substantial issues with the Executive Board.

The auditing firm KPMG AG Wirtschaftsprüfungsgesellschaft audited the financial statements, as well as the report on the state of affairs of the company, and issued an unqualified audit opinion. The consolidated financial statements and the report on the state of the corporation and the Group were issued in a joint audit by KPMG AG Wirtschaftsprüfungsgesellschaft. It issued an unqualified audit opinion. The financial statements, the consolidated financial statements, the report on the state of the company and of the Group, and the auditors' reports, were submitted and explained by the auditors to the Supervisory Board. After having conducted its own review, the Supervisory Board had no objections and approved the results of the audit.

The Supervisory Board also approved the financial statements, the consolidated financial statements, and the report on the state of the company and of the Group at its meeting on April 30, 2019. The financial statements have thus been approved. The Supervisory Board concurs with the Executive Board's dividend proposal.

Hamburg, April 30, 2019
The Supervisory Board



Daniel Weisser
Chairman

Consolidated Financial Statements 2018

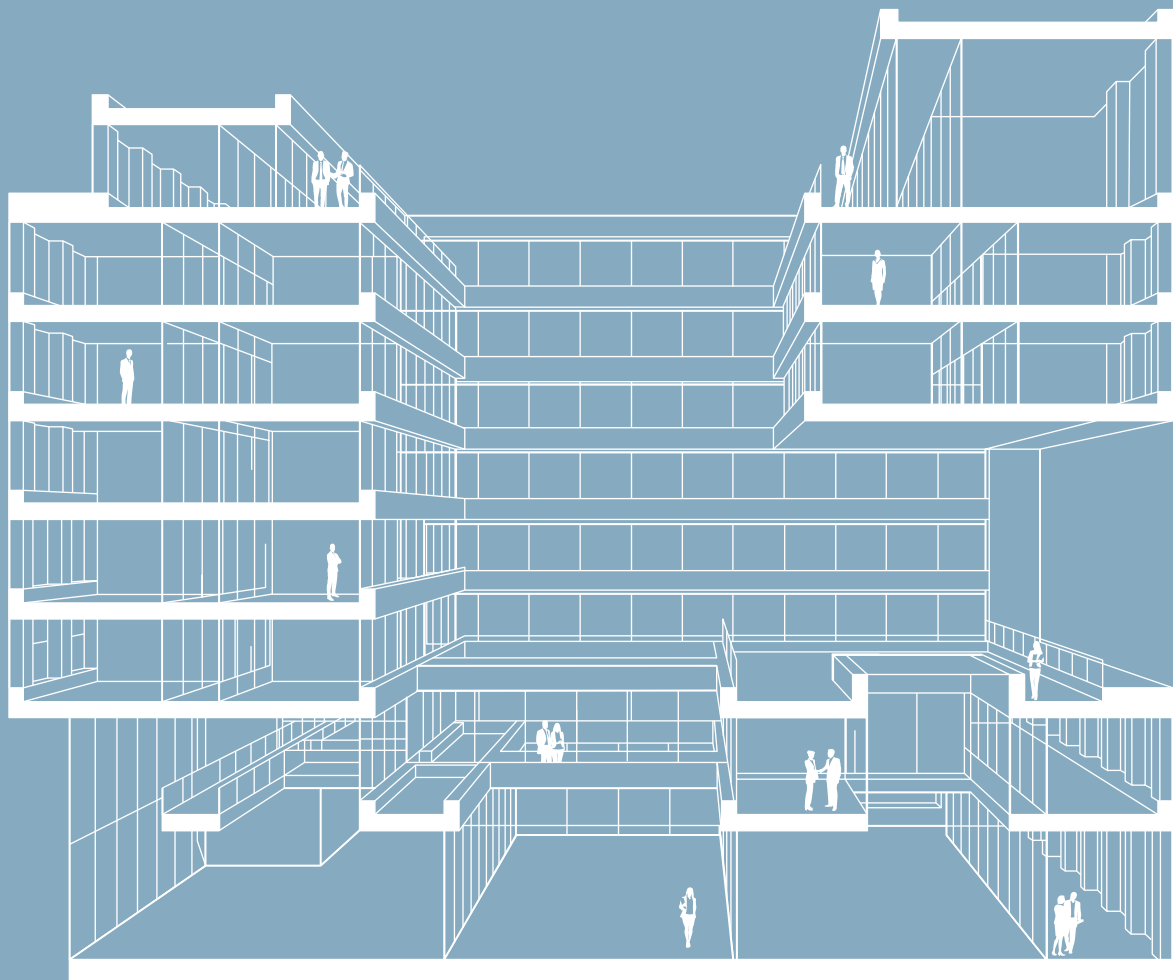

Consolidated Statement of Financial Position

as at 31 December, 2018

Assets (in k€)

A. Non-current assets

I. Intangible assets	189,894
II. Tangible assets	2,898,628
III. Investments accounted for using the equity method	313,868
IV. Other investments	1,223,114
V. Deferred taxes	49,817
VI. Non-current receivables and other assets	60,801
VII. Derivative financial instruments	21,282
	4,757,404

B. Current assets

I. Inventories	
1. Inventories, raw material and supplies	4,029
2. Inventories, goods and finished products	343,965
3. Advance payments	2
	347,996
II. Current receivables and other assets	
1. Trade receivables	865,310
2. Receivables – affiliated companies	95
3. Receivables – associated companies	8,491
4. Receivables owed by related companies	494
5. Other financial receivables and current assets	96,092
6. Current assets from other taxes	21,841
7. Current income tax receivables	50,765
8. Other current non-financial assets	18,394
	1,061,482
III. Derivative financial instruments	72,640
IV. Cash and cash equivalents	446,500
	1,928,618

C. Assets held for sale from disposal groups

	61,311
Total	6,747,332

Minor differences in the disclosure of individual amounts may occur due to rounding.



Liabilities and Shareholder's Equity (in k€)**A. Equity**

I. Common stock	250,000
II. Additional paid in capital	2,936
III. Revenue reserve	449,539
IV. Reserve for changes in value	-542,257
V. Reserve for revaluation	0
VI. Retained earnings	2,441,016
VII. Currency translation adjustments	52,602
VIII. Non-controlling interests	389,467
	3,043,303

B. Non-current liabilities

I. Current liabilities	
1. Non-current liabilities due to banks	703,289
2. Other non-current financial liabilities	636,342
3. Other non-current non-financial liabilities	810
4. Non-current tax liabilities	14
	1,340,455
II. Non-current provisions	163,486
III. Derivative financial instruments	19,877
IV. Deferred taxes	578,761
	2,102,579

C. Current liabilities

I. Current liabilities	
1. Current liabilities due to banks	317,254
2. Trade accounts payable	672,985
3. Current liabilities due to affiliated companies	141
4. Current liabilities due to associated companies	18,178
5. Current liabilities due to related companies	303
6. Other current financial liabilities	171,652
7. Other current non-financial liabilities	21,330
	1,201,843
II. Derivative financial instruments	29,767
III. Current accruals	
1. Tax accruals	31,123
2. Other current provisions and accrued liabilities	197,820
	228,943
IV. Current liabilities from other taxes	131,350
V. Current liabilities from income taxes	674
	1,592,577

D. Liabilities from disposal groups

	8,873
Total	6,747,332



Consolidated Statement of Comprehensive Income

for the period from January 1 to December 31, 2018

(in k€)

1. Revenues	13,285,765
2. Own work capitalized	7,772
3. Other operating income	246,678
4. Total operating revenues	13,540,215
5. Cost of sales	-12,387,299
a. Cost of raw materials and supplies and purchased goods	-12,070,656
b. Cost of purchased services	-316,643
6. Personnel expenses	-383,470
a. Wages and salaries	-325,457
b. Social security and expenses for pension commitments	-58,012
7. Other operating expenses	-455,543
8. Result from trading operations	313,903
9. Income from investments in subsidiaries	9,778
10. EBITDA	323,682
11. Amortization and depreciation on intangible and tangible fixed assets	-381,073
12. EBIT	-57,391
13. Income from fixed assets investments in securities and loans	85,121
14. Interest income and similar income	6,546
15. Interest expenses and similar expenses	-94,079
16. Result from changes in value of derivative financial instruments	21,472
17. Financial result	19,060
18. EBT	-38,331
19. Income tax	-63,262
20. Consolidated net result	-101,592
thereof:	
net result attributable to equity holders of the parent	-140,699
net result attributable to minority interests	39,107

Minor differences in the disclosure of individual amounts may occur due to rounding.

(in k€)

20. Consolidated net result	-101,592
Items that may be reclassified subsequently to profit and loss	
21. Exchange differences on translating foreign operations	63,426
22. Available-for-sale financial assets	-97,843
23. Cash flow hedges	1,495
24. Share of other comprehensive income of associates	-2,182
25. Income tax	12,382
thereof arising from cash flow hedges	0
thereof arising from associates	371
thereof available-for-sale financial assets	12,011
	-22,722
Items that will not be reclassified subsequently to profit and loss	
26. Actuarial losses arising from defined benefit obligations	504
27. Income tax relating to components of defined benefit obligations	-89
	415
28. Other comprehensive result for the year	-22,307
29. Total comprehensive result for the year	-123,899
thereof:	
comprehensive result attributable to equity holders of the parent	-160,268
comprehensive result attributable to minority interests	36,369



Independent Auditor's Report

Above we published the incomplete Marquard & Bahls AG's consolidated financial statements as of December 31, 2018. The consolidated financial statements as of December 31, 2018, comprise the consolidated statement of financial position, consolidated income statement, consolidated statement of comprehensive income, consolidated statement of changes in equity, consolidated statement of cash flows and the notes.

With regard to the complete consolidated financial statements as of December 31, 2018, and the group management report for the financial year 2018 the annual auditor has issued the following auditor's report:

"To Marquard & Bahls Aktiengesellschaft, Hamburg

Opinions

We have audited the consolidated financial statements of Marquard & Bahls Aktiengesellschaft, Hamburg and its subsidiaries (the Group), which comprise the consolidated statement of financial position as at December 31, 2018, the consolidated income statement, the consolidated statement of comprehensive income, the consolidated statement of changes in equity and the consolidated statement of cash flows for the financial year from January 1 to December 31, 2018, and the notes to the consolidated financial statements, including a summary of significant accounting policies. In addition, we have audited the combined management report for the single entity and the group ("group management report") of Marquard & Bahls Aktiengesellschaft for the financial year from January 1 to December 31, 2018.

In our opinion, on the basis of the knowledge obtained in the audit,

- the accompanying consolidated financial statements comply, in all material respects, with the IFRSs as adopted by the EU, and the additional requirements of German commercial law pursuant to Section 315e (1) HGB (Handelsgesetzbuch: German Commercial Code) and, in compliance with these requirements, give a true and fair view of the assets, liabilities, and financial position of the Group as at December 31, 2018, and of its financial performance for the financial year from January 1 to December 31, 2018, and
- the accompanying group management report as a whole provides an appropriate view of the Group's position. In all material respects, this group management report is consistent with the consolidated financial statements, complies with German legal requirements and appropriately presents the opportunities and risks of future development.

Pursuant to Section 322 (3) sentence 1 HGB, we declare that our audit has not led to any reservations relating to the legal compliance of the consolidated financial statements and the group management report.

Basis for the Opinions

We conducted our audit of the consolidated financial statements and of the group management report in accordance with Section 317 HGB and the German Generally Accepted Standards of Financial Statement Audits promulgated by the Institut der Wirtschaftsprüfer (Institute of Public Auditors in Germany) (IDW). Our responsibilities



under those requirements and principles are further described in the "Auditor's Responsibilities for the Audit of the Consolidated Financial Statements and of the Group Management Report" section of our auditor's report. We are independent of the group entities in accordance with the requirements of German commercial and professional law, and we have fulfilled our other German professional responsibilities in accordance with these requirements. We believe that the evidence we have obtained is sufficient and appropriate to provide a basis for our opinions on the consolidated financial statements and on the group management report.

Other Information

Management is responsible for the other information. The other information comprises the annual report, with the exception of the audited consolidated statement of financial position and the consolidated statement of comprehensive income and our auditor's report.

Our opinions on the consolidated financial statements and on the group management report do not cover the other information, and consequently we do not express an opinion or any other form of assurance conclusion thereon.

In connection with our audit, our responsibility is to read the other information and, in so doing, to consider whether the other information

- is materially inconsistent with the consolidated financial statements, with the group management report or our knowledge obtained in the audit, or
- otherwise appears to be materially misstated.

Responsibilities of Management and the Supervisory Board for the Consolidated Financial Statements and the Group Management Report

Management is responsible for the preparation of the consolidated financial statements that comply, in all material respects, with IFRSs as adopted by the EU and the additional requirements of German commercial law pursuant to Section 315e (1) HGB and that the consolidated financial statements, in compliance with these requirements, give a true and fair view of the assets, liabilities, financial position, and financial performance of the Group. In addition, management is responsible for such internal control as they, in accordance with German Legally Required Accounting Principles, have determined necessary to enable the preparation of consolidated financial statements that are free from material misstatement, whether due to fraud or error.

In preparing the consolidated financial statements, management is responsible for assessing the Group's ability to continue as a going concern. They also have the responsibility for disclosing, as applicable, matters related to going concern. In addition, they are responsible for financial reporting based on the going concern basis of accounting unless there is an intention to liquidate the Group or to cease operations, or there is no realistic alternative but to do so.

Furthermore, management is responsible for the preparation of the group management report that, as a whole, provides an appropriate view of the Group's position and is, in all material respects, consistent with the consolidated financial statements, complies with German legal requirements, and appropriately presents the opportunities and risks



of future development. In addition, management is responsible for such arrangements and measures (systems) as they have considered necessary to enable the preparation of a group management report that is in accordance with the applicable German legal requirements, and to be able to provide sufficient appropriate evidence for the assertions in the group management report.

The supervisory board is responsible for overseeing the Group's financial reporting process for the preparation of the consolidated financial statements and of the group management report.

Auditor's Responsibilities for the Audit of the Consolidated Financial Statements and of the Group Management Report

Our objectives are to obtain reasonable assurance about whether the consolidated financial statements as a whole are free from material misstatement, whether due to fraud or error, and whether the group management report as a whole provides an appropriate view of the Group's position and, in all material respects, is consistent with the consolidated financial statements and the knowledge obtained in the audit, complies with the German legal requirements and appropriately presents the opportunities and risks of future development, as well as to issue an auditor's report that includes our opinions on the consolidated financial statements and on the group management report.

Reasonable assurance is a high level of assurance, but is not a guarantee that an audit conducted in accordance with Section 317 HGB and in compliance with the German generally accepted standards for the audit of financial statements promulgated by the Institut der Wirtschaftsprüfer (IDW) will always detect a material misstatement. Misstatements can arise from fraud or error and are considered material if, individually or in the aggregate, they could reasonably be expected to influence the economic decisions of users taken on the basis of these consolidated financial statements and this group management report.

We exercise professional judgement and maintain professional scepticism throughout the audit. We also:

- identify and assess the risks of material misstatement of the consolidated financial statements and of the group management report, whether due to fraud or error, design and perform audit procedures responsive to those risks, and obtain audit evidence that is sufficient and appropriate to provide a basis for our opinions. The risk of not detecting a material misstatement resulting from fraud is higher than for one resulting from error, as fraud may involve collusion, forgery, intentional omissions, misrepresentations, or the override of internal controls.
- obtain an understanding of internal control relevant to the audit of the consolidated financial statements and of arrangements and measures (systems) relevant to the audit of the group management report in order to design audit procedures that are appropriate in the circumstances, but not for the purpose of expressing an opinion on the effectiveness of these systems.
- evaluate the appropriateness of accounting policies used by management and the reasonableness of estimates made by management and related disclosures.



- conclude on the appropriateness of management’s use of the going concern basis of accounting and, based on the audit evidence obtained, whether a material uncertainty exists related to events or conditions that may cast significant doubt on the Group’s ability to continue as a going concern. If we conclude that a material uncertainty exists, we are required to draw attention in the auditor’s report to the related disclosures in the consolidated financial statements and in the group management report or, if such disclosures are inadequate, to modify our respective opinions. Our conclusions are based on the audit evidence obtained up to the date of our auditor’s report. However, future events or conditions may cause the Group to cease to be able to continue as a going concern.
- evaluate the overall presentation, structure and content of the consolidated financial statements, including the disclosures, and whether the consolidated financial statements present the underlying transactions and events in a manner that the consolidated financial statements give a true and fair view of the assets, liabilities, financial position and financial performance of the Group in compliance with IFRSs as adopted by the EU and the additional requirements of German commercial law pursuant to Section 315e (1) HGB.
- obtain sufficient appropriate audit evidence regarding the financial information of the entities or business activities within the Group to express opinions on the consolidated financial statements and on the group management report. We are responsible for the direction, supervision and performance of the group audit. We remain solely responsible for our opinions.
- evaluate the consistency of the group management report with the consolidated financial statements, its conformity with (German) law, and the view of the Group’s position it provides.
- perform audit procedures on the prospective information presented by management in the group management report. On the basis of sufficient appropriate audit evidence we evaluate, in particular, the significant assumptions used by management as a basis for the prospective information, and evaluate the proper derivation of the prospective information from these assumptions. We do not express a separate opinion on the prospective information and on the assumptions used as a basis. There is a substantial unavoidable risk that future events will differ materially from the prospective information.

We communicate with those charged with governance regarding, among other matters, the planned scope and timing of the audit and significant audit findings, including any significant deficiencies in internal control that we identify during our audit.

Hamburg, March 29, 2019

KPMG AG
Wirtschaftsprüfungsgesellschaft

(Original German version signed by:)

(signature) Schmelzer
Wirtschaftsprüfer
(German Public Auditor)

(signature) Heckert
Wirtschaftsprüfer
(German Public Auditor)“



Marquard & Bahls AG

Hamburg, Germany

Oiltanking GmbH

Hamburg, Germany

Tank Storage Logistics Europe

Oiltanking Amsterdam B. V.
Amsterdam, Netherlands
Oiltanking Antwerp Gas Terminal
N.V.
Antwerp, Belgium
Oiltanking Bulgaria A.D.
Varna, Bulgaria
Oiltanking Copenhagen A/S
Copenhagen, Denmark
Oiltanking Deutschland
GmbH & Co. KG
Hamburg, Germany
Oiltanking Finance B. V.
Amsterdam, Netherlands
Oiltanking Finland Oy
Kotka, Finland
Oiltanking Ghent N. V.
Ghent, Belgium
Oiltanking Hungary Kft.
Budapest, Hungary
Oiltanking Malta Ltd.
Birzebbugia, Malta
Oiltanking Stolthaven Antwerp N. V.
Antwerp, Belgium
Oiltanking Tallinn AS
Tallinn, Estonia
Oiltanking Tanklager Waltershof
GmbH & Co. KG
Hamburg, Germany
Oiltanking Terneuzen B. V.
Terneuzen, Netherlands
TransTank GmbH
Gelsenkirchen, Germany

America

Açu Petroleo S. A.
Rio de Janeiro, Brazil
Colon Oil and Services S. A.
Panama City, Panama
Consortio Terminales
Lima, Peru
Logistica de Quimicos del Sur S.A.C.
Lima, Peru
Oiltanking Açu Serviços Ltda.
Rio de Janeiro, Brazil
Oiltanking Andina Services S.A.C.
Lima, Peru
Oiltanking Colombia S.A.
Bogota, Colombia
Oiltanking Colombia Servicios S.A.
Bogota, Colombia
Oiltanking Ebytem S.A.
Buenos Aires, Argentina
Oiltanking Galveston County, LLC
City of Wilmington, USA
Oiltanking Joliet LLC
Joliet, USA

Oiltanking Logistica Brasil Ltda.
Rio de Janeiro, Brazil
Oiltanking Mexico S. de R.L. de C.V.
Mexico City, Mexico
Oiltanking Peru S.A.C.
Lima, Peru
Oiltanking Terminais Ltda.
Rio de Janeiro, Brazil
Oiltanking Texas City L. P.
Texas City, USA
Terminales del Peru
Lima, Peru

Middle East & Africa

Oiltanking Terminals & Co. LLC
Sohar, Oman
Star Energy Resources Ltd.
Dubai, United Arab Emirates
Oiltanking Ghana Services Limited
Accra, Ghana
Oiltanking Grindrod Calulo
Proprietary Limited
Cape Town, South Africa
Oiltanking Matola S.A.
Matola, Mozambique
Oiltanking MOGS Saldanha (RF)
Proprietary Limited
Cape Town, South Africa

Asia

Daya Bay Public Pipe Rack Co. Ltd.
Huizhou, China
Huizhou Daya Bay Oiltanking
Petrochemical Public Jetty Co. Ltd.
Huizhou, China
IOT Infrastructure & Energy Services
Ltd.
Mumbai, India
Oiltanking Daya Bay Co. Ltd.
Huizhou, China
Oiltanking Helios Singapore Pte. Ltd.
Singapore
Oiltanking (Nanjing) Co. Ltd.
Nanjing, China
Oiltanking Singapore
Chemical Storage Pte. Ltd.
Singapore
Oiltanking Singapore Ltd.
Singapore
PT Oiltanking Karimun
Jakarta, Indonesia
PT Oiltanking Nusantara Persada
Jakarta, Indonesia
Zuari Indian Oiltanking Limited
Goa, India

Mabanaft GmbH & Co. KG

Hamburg, Germany

Trading

B.W.O.C. Limited
Weston-super-Mare, United Kingdom
Mabanaft Deutschland
GmbH & Co. KG
Hamburg, Germany
Mabanaft Energy Trading Inc.
Houston, USA
Mabanaft Natural Gas Products Ltd.
London, United Kingdom
Mabanaft Hungary Kft.
Budapest, Hungary
Mabanaft Limited
London, United Kingdom
Mabanaft Pte. Ltd.
Singapore

Retail

Petronord GmbH & Co. KG
Hamburg, Germany
AUSTROLUB GmbH & Co. KG
Vienna, Austria
Benol Energieservice GmbH
Frankfurt/Main, Germany
Böttcher Energie GmbH & Co. KG
Regensburg, Germany
Deglmann Energie GmbH & Co. KG
Weiden/Oberpfalz, Germany
EAG Energie Abrechnungs- und
Service GmbH
Hiddenhausen, Germany
Greiner GmbH
Wabern, Germany
Hartmann Energie GmbH
Oberleichtersbach, Germany
Hempelmann Wittemöller GmbH
Hiddenhausen, Germany
JB German Oil GmbH & Co. KG
Wittenburg, Germany
John Schmierstoff Service GmbH
Altlandsberg, Germany
Kaiser Söhne Mineralöl
GmbH & Co. KG
Arnsberg, Germany
Keck Energieservice GmbH & Co. KG
Brakel, Germany
Keck Schmierstoffservice
GmbH & Co. KG
Brakel, Germany
Kiessling Energie GmbH & Co. KG
Lauterhofen, Germany
Klindworth-Kronol Energie GmbH
Hamburg, Germany
Lipps Energie GmbH
Hagen, Germany
LSA Lubes Services GmbH & Co. KG
Vienna, Austria
LTH Tank- und Haustechnik GmbH
Purkersdorf, Austria
Mabanol GmbH & Co. KG
Hamburg, Germany

Mabanol Bitumen GmbH & Co. KG
Hamburg, Germany

Mabanol
Schmierstoffservice GmbH & Co. KG
Bremen, Germany

Manfred Mayer MMM Mineralöl
Vertriebsgesellschaft m.b.H.
Neudörfel, Austria

Mühlenbruch Stinnes TOTAL GmbH
Bremen, Germany

NordBit GmbH & Co. KG
Hamburg, Germany

Oiltech Lubes Service
GmbH & Co. KG
Erkrath-Unterfeldhaus, Germany

Petrocargo Mineralöl-Logistik GmbH
Hiddenhausen, Germany

PS Olje AB
Halmstad, Sweden

Schmidt Energiehandel GmbH
Ascheberg-Herbern, Germany

Staack Pooltankstellen
GmbH & Co. KG
Hamburg, Germany

Stockholms Diesel & Oljehandel AB
Bromma/Stockholm, Sweden

Swelube AB
Angered, Sweden

Thomas Silvey Ltd.
Bristol, United Kingdom

Uhlenbruck Energie GmbH & Co. KG
Mühlheim an der Ruhr, Germany

ZIEGLMEIER Energie GmbH
Schrobenhausen, Germany

OIL! Tankstellen GmbH & Co. KG
Hamburg, Germany

OIL! tank & go ApS
Vejle, Denmark

OIL! Tankstellen AG
Rüti, Switzerland

OIL Tankstellen GmbH
Vienna, Austria

Tirex Petrol S. A.
Chisinau, Moldova

BAT Auerswalde Nord
GmbH & Co. KG
Heidenau, Germany

Bunkering

Bomin Bunker Holding
GmbH & Co. KG
Hamburg, Germany

BOMIN Bunker Oil Corp.
Houston, USA

Bomin Deutschland GmbH & Co. KG
Hamburg, Germany

Skytanking Holding GmbH

Hamburg, Germany

Hydrant Refuelling System NV
Zaventem, Belgium

IndianOil Skytanking Limited
Bangalore, India

IndianOil Skytanking Delhi Limited
Delhi, India

Luxfuel S. A.
Luxembourg

Skytanking Austria GmbH
Vienna, Austria

Skytanking Calulo (Pty) Ltd.
Bryanston, South Africa

Skytanking Frankfurt GmbH
Frankfurt, Germany

Skytanking GmbH
Zurich, Switzerland

Skytanking GmbH & Co. KG
Hamburg, Germany

Skytanking Germany GmbH & Co. KG
Hamburg, Germany

Skytanking Limited
Birzebbugia, Malta

Skytanking Munich GmbH & Co. KG
Hamburg, Germany

Skytanking North America, Inc.
Houston, USA

Skytanking N.V.
Zaventem, Belgium

Skytanking Ovenon
Havacilik Hizmetleri A.S.
Istanbul, Turkey

Skytanking S. R. L.
Fiumicino, Italy

Skytanking Stuttgart GmbH & Co. KG
Hamburg, Germany

S & JD Robertson North Air Ltd.
Aberdeen, United Kingdom

United Bulk Terminals
USA Inc.
Houston, USA

United Bulk Terminals Davant LLC
Davant, USA

UBT Dupré Corpus Christi, LLC
Corpus Christi, USA

GMA Gesellschaft für
Mineralöl-Analytik und
Qualitätsmanagement
mbH + Co. KG
Frankfurt/Main, Germany

natGAS Aktiengesellschaft
Potsdam, Germany

Addresses



Marquard & Bahls AG

Koreastraße 7 20457 Hamburg Germany
Phone + 49 40 370 04-0 Fax + 49 40 370 04-7242 www.marquard-bahls.com



Oiltanking GmbH

Koreastraße 7 20457 Hamburg Germany
Phone + 49 40 370 04-0 Fax + 49 40 370 04-7499 www.oiltanking.com



Mabanft GmbH & Co. KG

Koreastraße 7 20457 Hamburg Germany
Phone + 49 40 370 04-0 Fax + 49 40 370 04-7352 www.mabanaft.com



Skytanking Holding GmbH

Koreastraße 7 20457 Hamburg Germany
Phone + 49 40 370 04-7454 Fax + 49 40 370 04-7379 www.skytanking.com



United Bulk Terminals USA Inc.

Murphy Building, 4th Floor, 9805 Katy Freeway Houston, TX 77024 USA
Phone +1 281 457-7900 Fax +1 281 457-7917 www.unitedbulkterminals.com



GMA - Gesellschaft für Mineralöl-Analytik und Qualitätsmanagement mbH + Co. KG

Koreastraße 7 20457 Hamburg Germany
Phone + 49 40 370 04-7159 Fax + 49 40 370 04-7299 www.gma-analytik.de



natGAS Aktiengesellschaft

Jägerallee 37 H 14469 Potsdam Germany
Phone + 49 331 20 04-0 Fax + 49 331 20 24-199 www.natgas.de



Colophon

Publisher

Marquard & Bahls AG

Text & Coordination

Kathrin Gieseke, Heidi Pipo, Jörg Walter
Marquard & Bahls AG, Corporate Communication

Design

Alwin Wehsling, Projekt 7 (Hamburg)

Printing

Druckerei Siepmann GmbH (Hamburg)

Paper: Inacard 330 g/m² and LuxoArt Samt 150 g/m²
Printed climate neutrally, Id-No. COB-71673/2019



Print run: 500 German und 1,000 English

This annual report is also published in German,
the German version is authoritative.

www.marquard-bahls.com
communication@marquard-bahls.com



